

GENERATOR INTERCONNECTION APPLICATION
 FOR ALL PROJECTS WITH AGGREGATE GENERATOR OUTPUT OF
 MORE THAN 150 KW BUT LESS THAN OR EQUAL TO 550 KW
 Also Serves as Application for Category 3 Net Metering
 (Note: Category 3 Net Metering Program only available to Methane Digester Projects)

Electric Utility Contact Information

Detroit Edison Company
 Interconnection Coordinator
 One Energy Plaza, SB 323
 Detroit, Mi 48226
 Interconnection Hotline: 313.235.4333
 Interconnection Email: interconnect@dteenergy.com

For Office Use Only
Application No. _____
Date & Time Application Received

Customer / Account Information

Electric Utility Customer Information: (As shown on utility bill)

Customer Name (Last, First, Middle):
 Customer Mailing Address:

Customer E-Mail Address: (optional)
 Electric Service Account #
 Electric Service Meter Number:

Are you applying for the Net Metering Program?

Yes No

Are you interested in selling Renewable Energy Credits (REC's)

Yes No

Will you have an Alternative Electric Supplier?

Notes: Enter name ONLY if your energy is supplied by a 3rd party, not the utility.
 You must apply to both the Distribution Utility and your Alternate Energy Provider (if applicable) for Net Metering

Yes No

Alternative Electric Supplier Name

--

Generation System Site Information

Physical Site Service Address (if not Billing Address):

--

Annual Site Requirements Without Generation in Kilowatthours

	kWh/year
	kW/year

Peak Annual Site Demand in Kilowatts (only for customers billed on demand rates)

Attached Site Plan:

Page #
Page #

Attached Electrical One-Line Drawing (See the Appendix D for a sample Inverter Type Project)

(Per MPSC Order in Case No. U-15787- The one-line diagram must be signed and sealed by a licensed professional engineer, licensed in the State of Michigan or by an electrical contractor licensed by the State of Michigan with the electrical contractor's license number noted on the diagram.)

Synchronous/Induction Generators: Must fill out Appendix A or B and provide a Detail One-Line Diagram

See Appendix E and F for a sample the Detail One-Line Diagram for Synchronous or Induction projects
 Note: The following information on these system components shall appear on the preliminary Detail One-Line Diagram

Page #

- Breakers - Rating, location and normal operating status (open or closed)
- Buses - Operating voltage
- Capacitors - Size of bank in Kvar
- Circuit Switchers - Rating, location and normal operating status (open or closed)
- Current Transformers - Overall ratio, connected ratio
- Fuses - normal operating status, rating (Amps), type
- Generators - Capacity rating (kVA), location, type, method of grounding
- Grounding Resistors - Size (ohms), current (Amps)
- Isolating transformers - Capacity rating (kVA), location, impedance, voltage ratings, primary and secondary connections and method of grounding
- Potential Transformers - Ratio, connection
- Reactors - Ohms/phase
- Relays - Types, quantity, IEEE device number, operator lines indicating the device initiated by the relays.
- Switches - Location and normal operating status (open or closed), type, rating
- Tagging Point - Location, identification

GENERATOR INTERCONNECTION APPLICATION
 FOR ALL PROJECTS WITH AGGREGATE GENERATOR OUTPUT OF
 MORE THAN 150 KW BUT LESS THAN OR EQUAL TO 550 KW
 Also Serves as Application for Category 3 Net Metering
 (Note: Category 3 Net Metering Program only available to Methane Projects)

Generation System - Manufacturer Information

System Type (Solar, Wind, Biomass, Methane Digester, etc):	<input type="text"/>
Generator Type (Inverter, Induction, Synchronous):	<input type="text"/>
Generator Nameplate Rating:	<input type="text"/> kW
Expected Annual Output in Kilowatthours	<input type="text"/> kWh/year
A.C. Operating Voltage:	<input type="text"/>
Wiring Configuration (Single Phase, Three Phase):	<input type="text"/>
Certified Test Record No.(Testing to standard UL1741 scope 1.1a)	<input type="text"/>

Inverter Based Systems:

Manufacturer	<input type="text"/>
Model (Name / Number)	<input type="text"/>
Inverter Power Rating (kW)	<input type="text"/>

Induction & Synchronous Based Systems

Manufacturer	<input type="text"/>
Model (Name / Number)	<input type="text"/>

Installation Information

Project Single Point of Contact: (Electric Utility Customer, Developer, or other)

Name:	<input type="text"/>
Company (If Applicable):	<input type="text"/>
Phone Number:	<input type="text"/>
E-Mail Address:	<input type="text"/>
Requested In Service Date:	<input type="text"/>
Licensed Contractor (Name of Firm or Self):	<input type="text"/>
Contractor Name (Last, First, MI):	<input type="text"/>
Contractor Phone #:	<input type="text"/>
Contractor E-Mail:	<input type="text"/>

Customer and Contractor Signature and Fees

<input type="checkbox"/> Attached \$150 Interconnection Application Fee or		
<input type="checkbox"/> Attached \$100 combined Interconnection & Net Metering Program application fees	(Check # / Money Order #)	<input type="text"/>
(\$75 Interconnection Application Fee plus \$25 fee required if selecting net metering)		

(Sign and Return complete application with Application Fee to Electric Utility Contact)
To the best of my knowledge, all the information provided in this Application Form is complete and correct.

Customer

Project Developer/Contractor (If Applicable)

Note: Refer to the applicable "Michigan Electric Utility Generator Interconnection Requirements" for a detailed explanation of the Interconnection Process, Fees, Timelines, and Technical Requirements.

APPENDIXES

- Appendix A: Technical Information for Synchronous-Type Generators
- Appendix B: Technical Information for Induction-Type Generators
- Appendix C: Sample Site Plan
- Appendix D: Sample One-Line diagram for Inverter Type Project
- Appendix E: Sample One-Line diagram for Synchronous Type Project
- Appendix F: Sample One-Line diagram for Induction Type Project

Appendix A

Synchronous Generators

Generator Information

- a. Generator Nameplate Voltage
- b. Generator Nameplate Watts or Volt-Amperes
- c. Generator Nameplate Power Factor (pf)
- d. RPM

a.
b.
c.
d.

Technical Information

- e. Minimum and Maximum Acceptable Terminal Voltage
- f. Direct axis reactance (saturated)
- g. Direct axis reactance (unsaturated)
- h. Quadrature axis reactance (unsaturated)
- i. Direct axis transient reactance (saturated)
- j. Direct axis transient reactance (unsaturated)
- k. Quadrature axis transient reactance (unsaturated)
- l. Direct axis sub-transient reactance (saturated)
- m. Direct axis sub-transient reactance (unsaturated)
- n. Leakage Reactance
- o. Direct axis transient open circuit time constant
- p. Quadrature axis transient open circuit time constant
- q. Direct axis subtransient open circuit time constant
- r. Quadrature axis subtransient open circuit time constant
- s. Open Circuit saturation curve
- t. Reactive Capability Curve showing overexcited and underexcited limits (Reactive Information if non-synchronous)
- u. Excitation System Block Diagram with values for gains and time constants (Laplace transforms)
- v. Short Circuit Current contribution from generator at the Point of Common Coupling
- w. Rotating inertia of overall combination generator, prime mover, couplers and gear drives
- x. Station Power load when generator is off-line, Watts, pf
- y. Station Power load during start-up, Watts, pf
- z. Station Power load during operation, Watts, pf

e.
f.
g.
h.
i.
j.
k.
l.
m.
n.
o.
p.
q.
r.
s.
t.
u.
v.
w.
x.
y.
z.

Appendix B

Induction Generators

Generator Information

- a. Generator Nameplate Voltage
- b. Generator Nameplate Watts or Volt-Amperes
- c. Generator Nameplate Power Factor (pf)
- d. RPM

a.
b.
c.
d.

Technical Information

- e. Synchronous Rotational Speed
- f. Rotation Speed at Rated Power
- g. Slip at Rated Power
- h. Minimum and Maximum Acceptable Terminal Voltage
- i. Motoring Power (kW)
- j. Neutral Grounding Resistor (If Applicable)
- k. I_2^2t or K (Heating Time Constant)
- l. Rotor Resistance
- m. Stator Resistance
- n. Stator Reactance
- o. Rotor Reactance
- p. Magnetizing Reactance
- q. Short Circuit Reactance
- r. Exciting Current
- s. Temperature Rise
- t. Frame Size
- u. Design Letter
- v. Reactive Power Required in Vars (No Load)
- w. Reactive Power Required in Vars (Full Load)
- x. Short Circuit Current contribution from generator at the Point of Common Coupling
- y. Rotating inertia, H in Per Unit on kVA Base, of overall combination generator, prime mover, couplers and gear drives
- z. Station Power load when generator is off-line, Watts, pf
- aa. Station Power load during start-up, Watts, pf
- bb. Station Power load during operation, Watts, pf

e.
f.
g.
h.
i.
j.
k.
l.
m.
n.
o.
p.
q.
r.
s.
t.
u.
v.
w.
x.
y.
z.
aa.
bb.

Appendix C
Sample Site Plan

SITE PLAN

APPLICANT	
ADDRESS	
CITY/TOWN	SIGNATURE

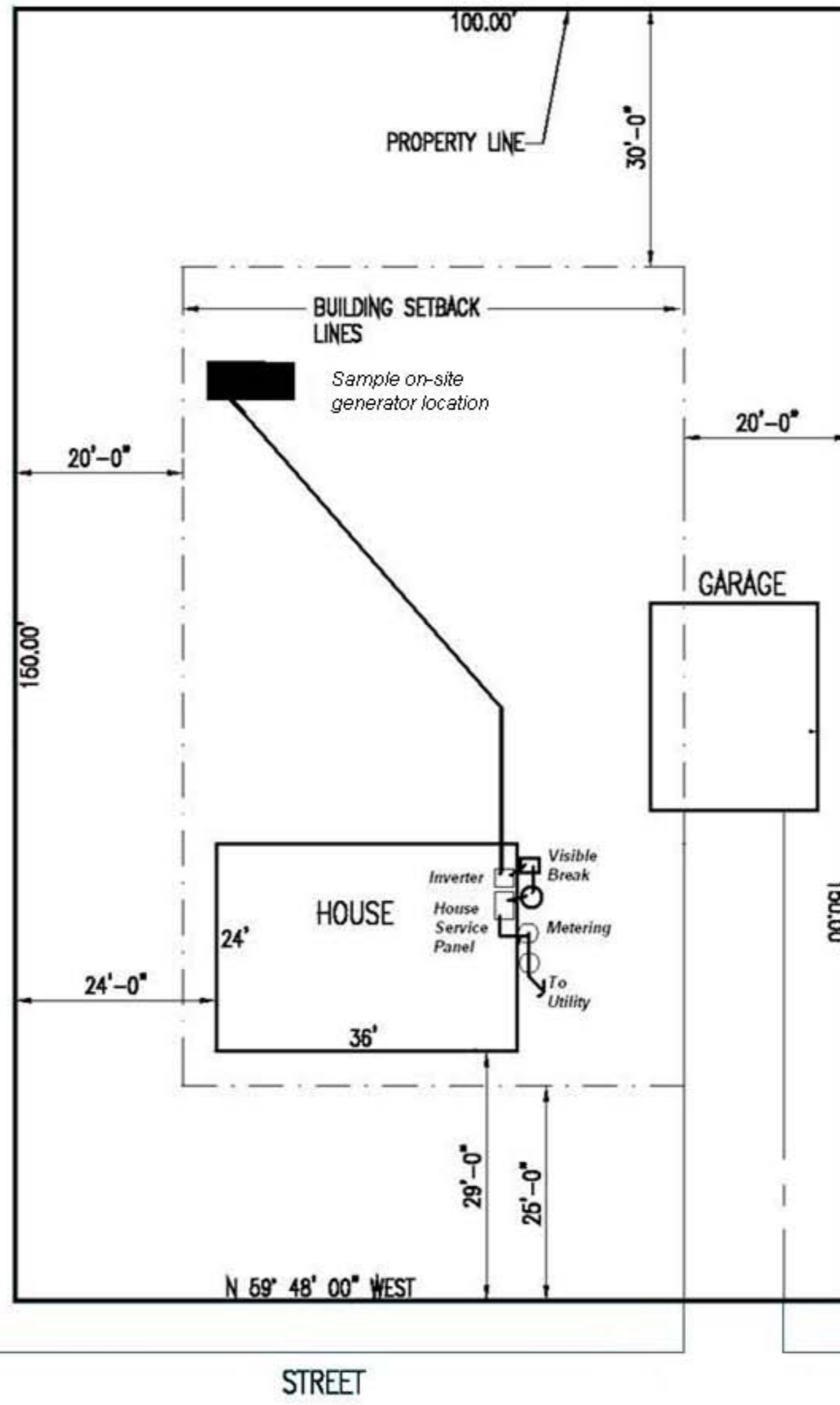

Appendix D

Inverter Generators

Sample One-Line Drawing

UL 1741 Scope 1.1A Compliant

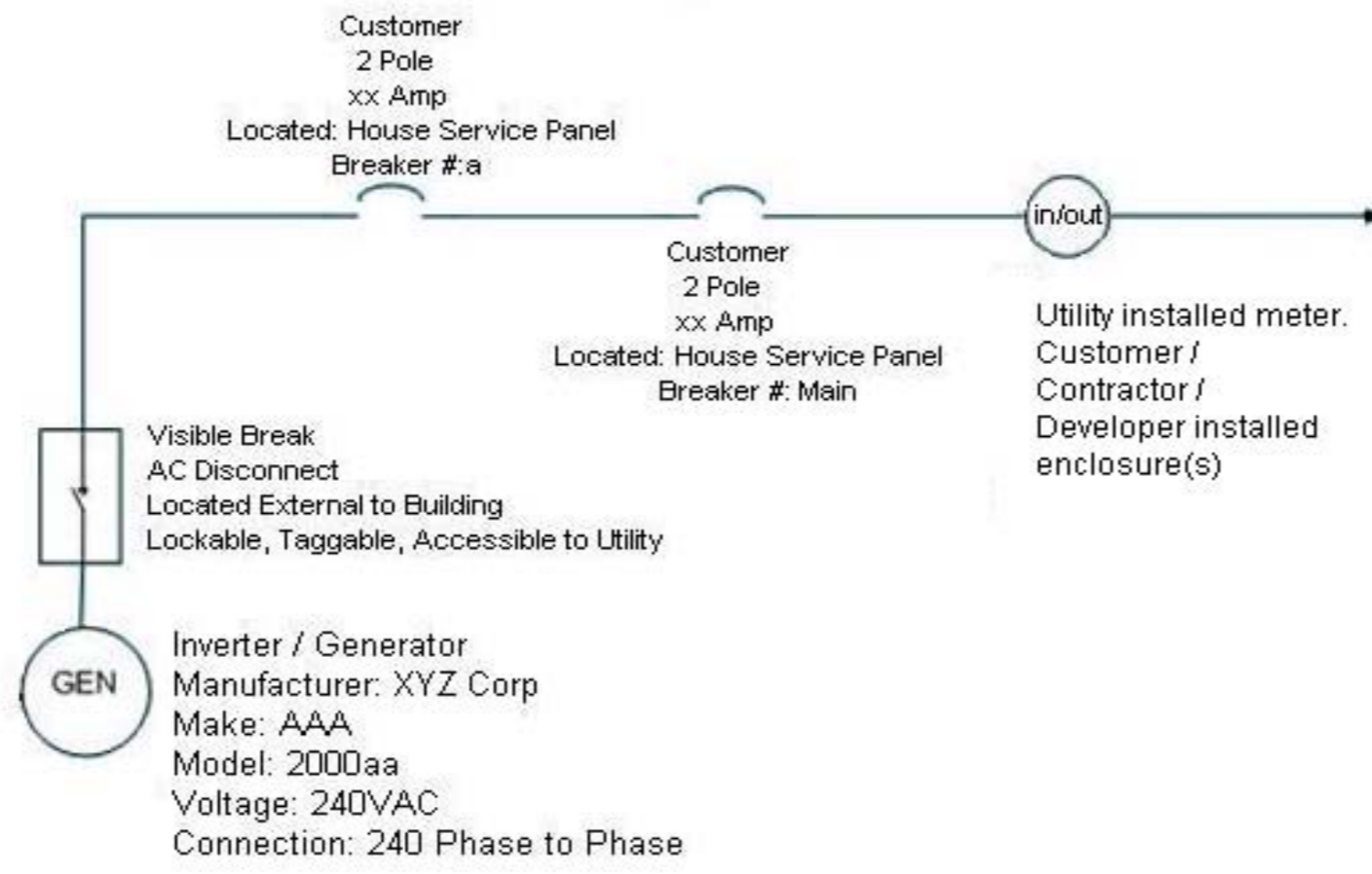

Legible Hand Drawn One-Line is acceptable

One - Line Diagram

Name of the Licensed Contractor /PE _____
Contractor License Number _____
Address _____
Signature _____

Appendix E

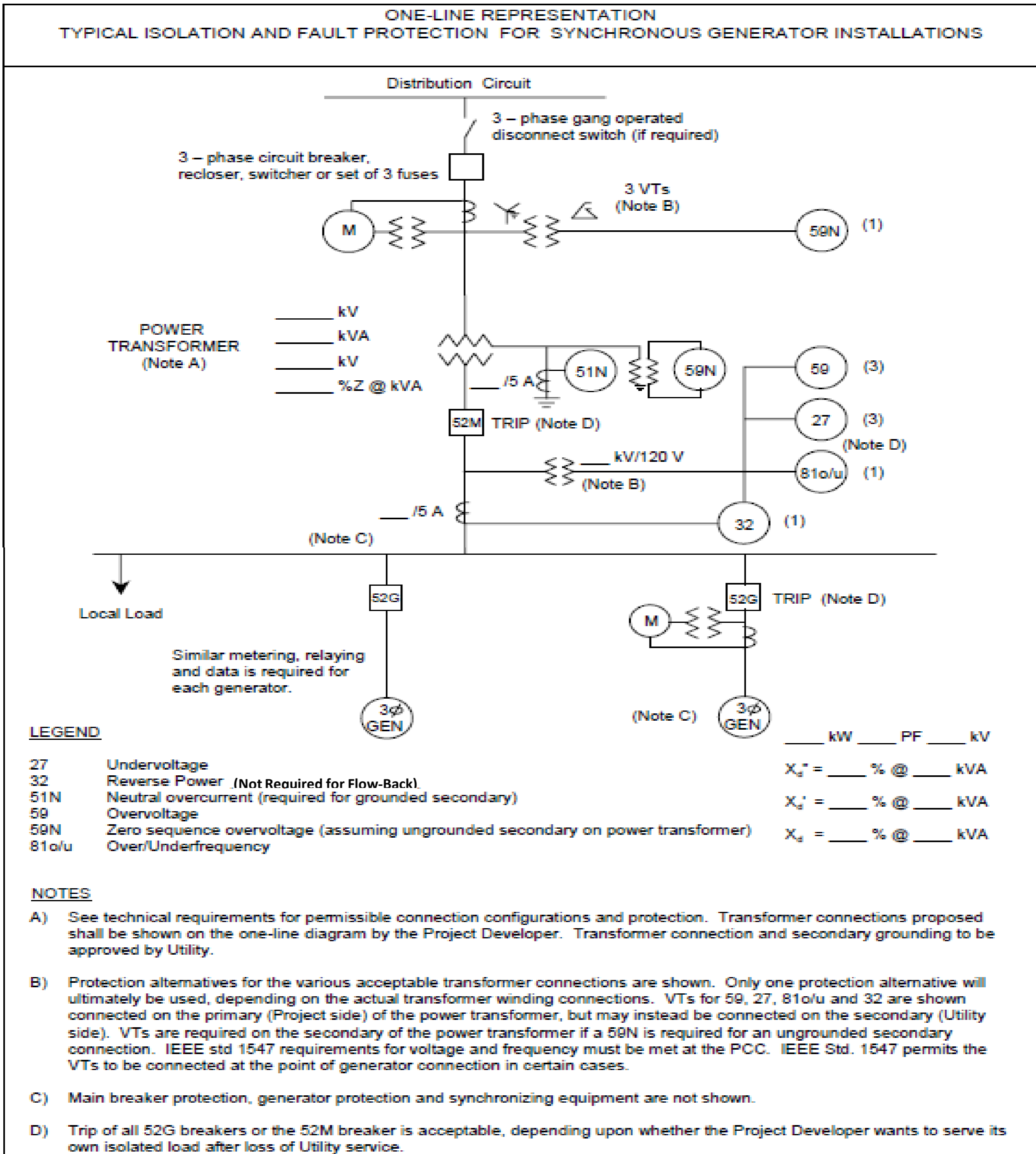

One - Line Diagram

Name of the Licensed Contractor /PE _____
 Contractor License Number _____
 Address _____
 Signature _____

