

GENERATOR INTERCONNECTION APPLICATION
 FOR ALL PROJECTS WITH AGGREGATE GENERATOR OUTPUT OF
 MORE THAN 2 MW

Required Information for all Projects Types

1. Customer's Proof of General Liability Insurance for a minimum of \$1,000,000

(Per MPSC Order in Case No. U-15787 - Customer must maintain a minimum of \$1,000,00 General Liability Insurance.)

Page #

2. Attached Site Plan:

Page #

3. Attached Electrical One-Line Drawing:

(Per MPSC Order in Case No. U-15787, the one-line diagram must be signed and sealed by a licensed professional engineer, licensed in the State of Michigan)

Page #

4. Attached Electrical Three-Line Drawing:

Page #

5. Attached Specification for Equipment

Page #

6. Applicable Technical Appendix (A-C)

Page #

Note: The following information on these system components shall appear on the preliminary Detail One-Line Diagram

- Breakers - Rating, location and normal operating status (open or closed)
- Buses - Operating voltage
- Capacitors - Size of bank in Kvar
- Circuit Switchers - Rating, location and normal operating status (open or closed)
- Current Transformers - Overall ratio, connected ratio
- Fuses - normal operating status, rating (Amps), type
- Generators - Capacity rating (kVA), location, type, method of grounding
- Grounding Resistors - Size (ohms), current (Amps)
- Isolating transformers - Capacity rating (kVA), location, impedance, voltage ratings, primary and secondary connections and method of grounding
- Potential Transformers - Ratio, connection
- Reactors - Ohms/phase
- Relays - Types, quantity, IEEE device number, operator lines indicating the device initiated by the relays.
- Switches - Location and normal operating status (open or closed), type, rating
- Tagging Point - Location, identification

Customer and Contractor Signature and Fees

Attached \$500 Interconnection Application Fee

(Check #/ Money Order #)

--

(Sign and Return complete application with Application Fee to Electric Utility Contact)

To the best of my knowledge, all the information provided in this Application Form is complete and correct.

_____ **Customer**

_____ **Project Developer/Contractor (If Applicable)**

Note: Refer to the applicable "Michigan Electric Utility Generator Interconnection Requirements" for a detailed explanation of the Interconnection Process, Fees, Timelines, and Technical Requirements.

APPENDIXES

- APPENDIX A: Technical Information for Synchronous-Type Generators
- APPENDIX B: Technical Information for Induction-Type Generators
- APPENDIX C: Technical Information for Inverter-Type Generators
- APPENDIX D: Sample One-Line diagram for Synchronous Type Project
- APPENDIX E: Sample One-Line diagram for Induction Type Project
- APPENDIX F: Sample One-Line diagram for Inverter Type Project

Appendix A

Synchronous Generators

Generator Information

- a. Generator Nameplate Voltage
- b. Generator Nameplate Watts or Volt-Amperes
- c. Generator Nameplate Power Factor (pf)
- d. RPM

a.
b.
c.
d.

Technical Information

- e. Minimum and Maximum Acceptable Terminal Voltage
- f. Direct axis reactance (saturated)
- g. Direct axis reactance (unsaturated)
- h. Quadrature axis reactance (unsaturated)
- i. Direct axis transient reactance (saturated)
- j. Direct axis transient reactance (unsaturated)
- k. Quadrature axis transient reactance (unsaturated)
- l. Direct axis sub-transient reactance (saturated)
- m. Direct axis sub-transient reactance (unsaturated)
- n. Leakage Reactance
- o. Direct axis transient open circuit time constant
- p. Quadrature axis transient open circuit time constant
- q. Direct axis subtransient open circuit time constant
- r. Quadrature axis subtransient open circuit time constant
- s. Open Circuit saturation curve
- t. Reactive Capability Curve showing overexcited and underexcited limits (Reactive Information if non-synchronous)
- u. Excitation System Block Diagram with values for gains and time constants (Laplace transforms)
- v. Short Circuit Current contribution from generator at the Point of Common Coupling
- w. Rotating inertia of overall combination generator, prime mover, couplers and gear drives
- x. Station Power load when generator is off-line, Watts, pf
- y. Station Power load during start-up, Watts, pf
- z. Station Power load during operation, Watts, pf

e.
f.
g.
h.
i.
j.
k.
l.
m.
n.
o.
p.
q.
r.
s.
t.
u.
v.
w.
x.
y.
z.

Appendix B

Induction Generators

Generator Information

- a. Generator Nameplate Voltage
- b. Generator Nameplate Watts or Volt-Amperes
- c. Generator Nameplate Power Factor (pf)
- d. RPM

a.
b.
c.
d.

Technical Information

- e. Synchronous Rotational Speed
- f. Rotation Speed at Rated Power
- g. Slip at Rated Power
- h. Minimum and Maximum Acceptable Terminal Voltage
- i. Motoring Power (kW)
- j. Neutral Grounding Resistor (If Applicable)
- k. I_2^2t or K (Heating Time Constant)
- l. Rotor Resistance
- m. Stator Resistance
- n. Stator Reactance
- o. Rotor Reactance
- p. Magnetizing Reactance
- q. Short Circuit Reactance
- r. Exciting Current
- s. Temperature Rise
- t. Frame Size
- u. Design Letter
- v. Reactive Power Required in Vars (No Load)
- w. Reactive Power Required in Vars (Full Load)
- x. Short Circuit Current contribution from generator at the Point of Common Coupling
- y. Rotating inertia, H in Per Unit on kVA Base, of overall combination generator, prime mover, couplers and gear drives
- z. Station Power load when generator is off-line, Watts, pf
- aa. Station Power load during start-up, Watts, pf
- bb. Station Power load during operation, Watts, pf

e.
f.
g.
h.
i.
j.
k.
l.
m.
n.
o.
p.
q.
r.
s.
t.
u.
v.
w.
x.
y.
z.
aa.
bb.

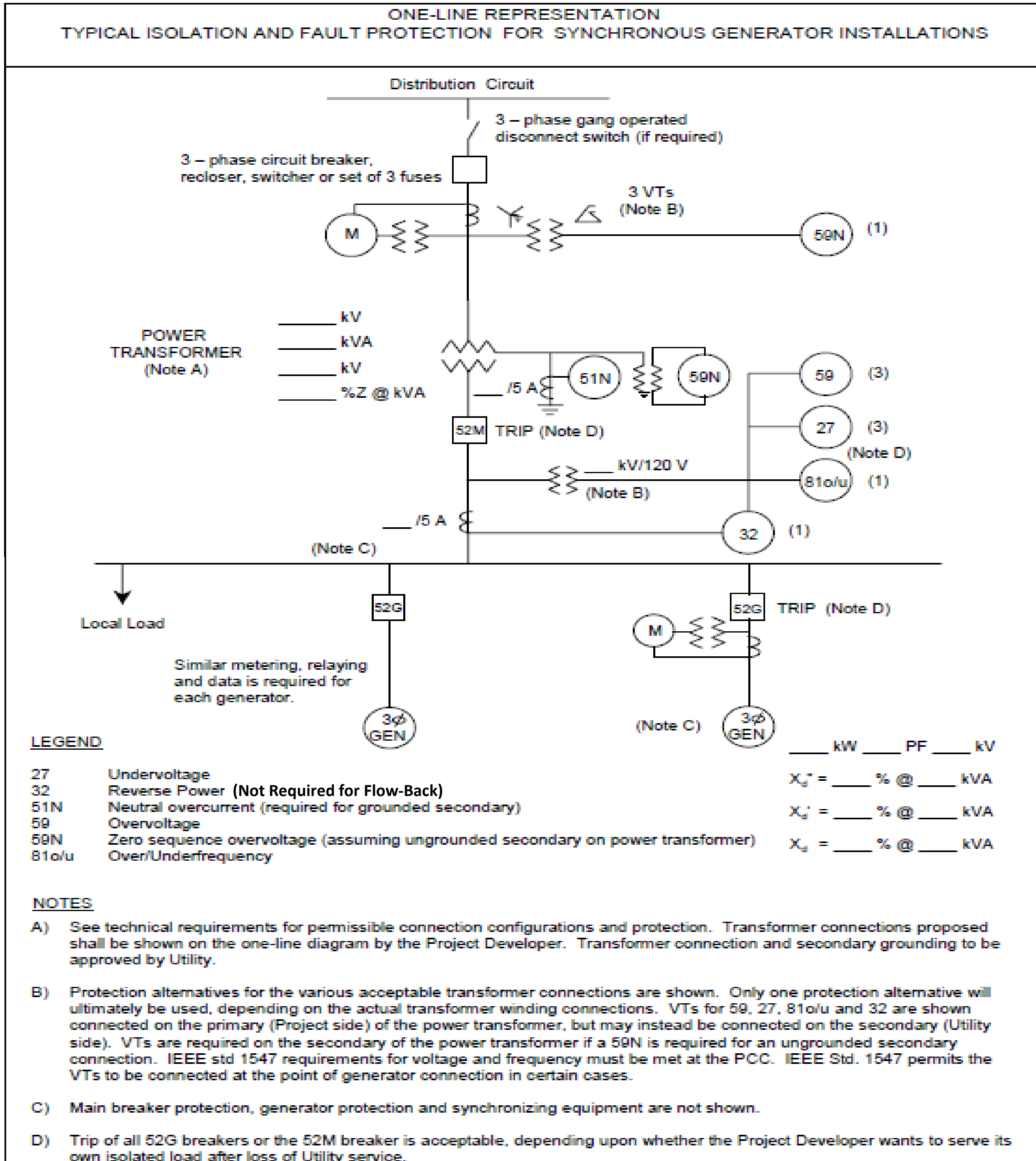

One - Line Diagram

Name of the Licensed Professional Engineer _____
 PE License Number _____
 Address _____
 Signature _____

Appendix E

ONE-LINE REPRESENTATION
TYPICAL ISOLATION AND FAULT PROTECTION FOR INDUCTION GENERATOR INSTALLATIONS

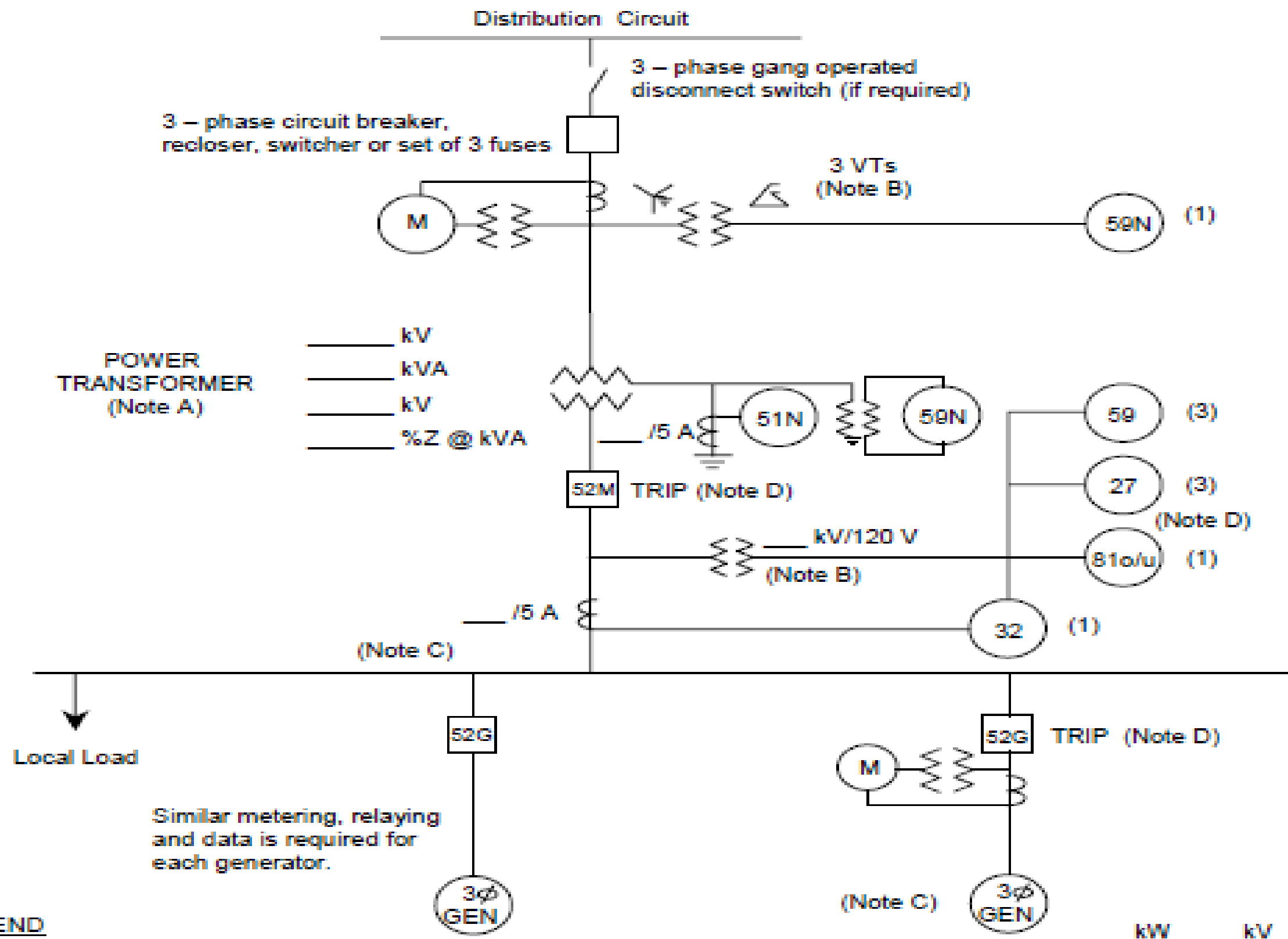

LEGEND

- 27 Undervoltage
- 32 Reverse Power (Not Required for Flow-Back)
- 51N Neutral overcurrent (required for grounded secondary)
- 59 Overvoltage
- 59N Zero sequence overvoltage (assuming ungrounded secondary on power transformer)
- 81o/u Over/Underfrequency

NOTES

- A) See technical requirements for permissible connection configurations and protection. Transformer connections proposed shall be shown on the one-line diagram by the Project Developer. Transformer connection and secondary grounding to be approved by Utility.
- B) Protection alternatives for the various acceptable transformer connections are shown. Only one protection alternative will ultimately be used, depending on the actual transformer winding connections. VTs for 59, 27, 81o/u and 32 are shown connected on the primary (Project side) of the power transformer, but may instead be connected on the secondary (Utility side). VTs are required on the secondary of the power transformer if a 59N is required for an ungrounded secondary connection. IEEE std 1547 requirements for voltage and frequency must be met at the PCC. IEEE Std. 1547 permits the VTs to be connected at the point of generator connection in certain cases.
- C) Main breaker protection, generator protection and synchronizing equipment are not shown.
- D) Trip of all 52G breakers or the 52M breaker is acceptable, depending upon whether the Project Developer wants to serve its own isolated load after loss of Utility service.

One - Line Diagram

Name of the Licensed Professional Engineer _____
 PE License Number _____
 Address _____

**ONE-LINE REPRESENTATION
TYPICAL ISOLATION AND FAULT PROTECTION FOR INVERTER GENERATOR INSTALLATIONS**

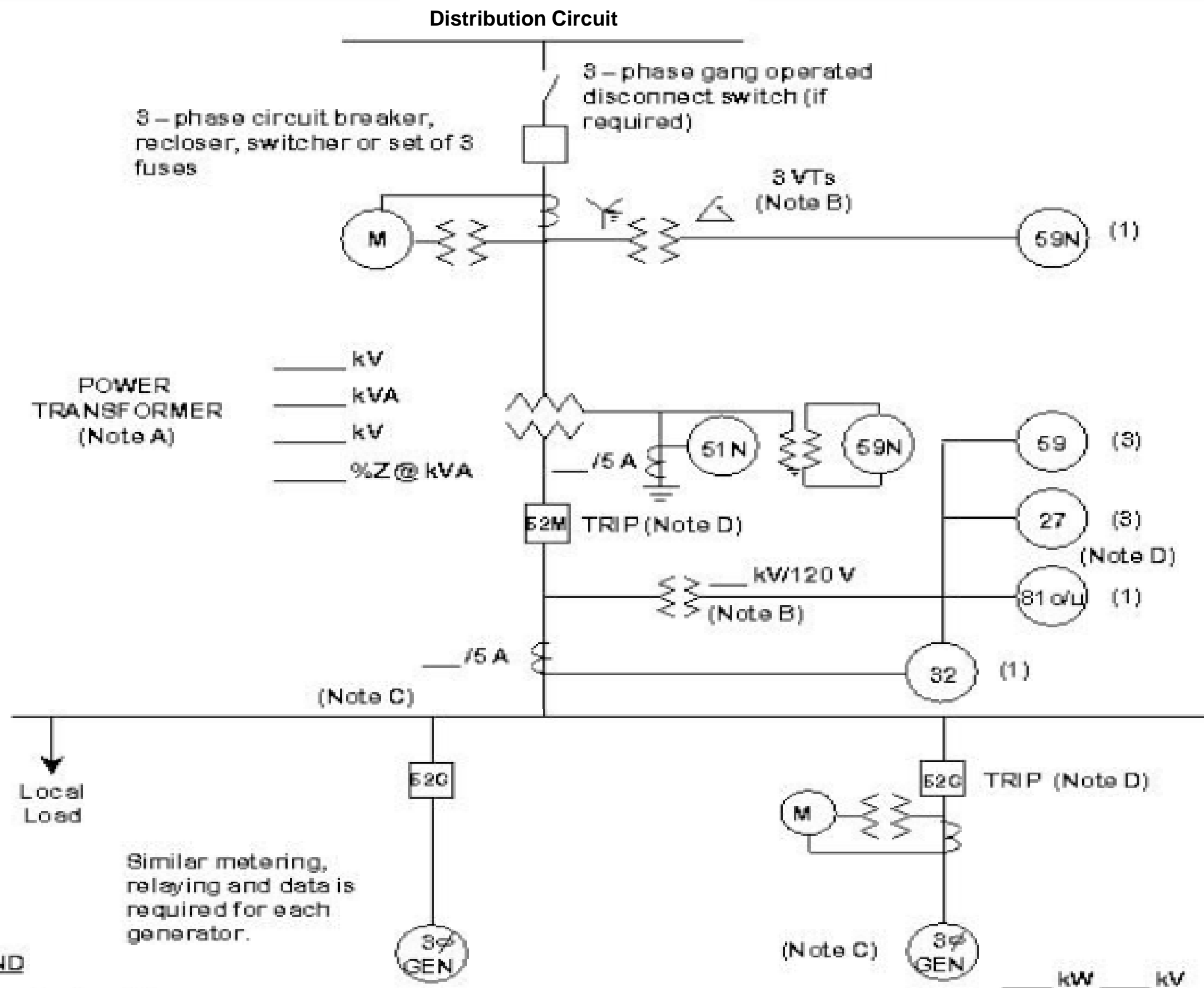

LEGEND

- 27 Undervoltage
- 32 Reverse Power (Not Required for Flow-Back)
- 51N Neutral overcurrent (required for grounded secondary)
- 59 Overvoltage
- 59N Zero sequence overvoltage (assuming ungrounded secondary on power transformer)
- 81o/u Over/Underfrequency

NOTES

- A) See technical requirements for permissible connection configurations and protection. Transformer connections proposed shall be shown on the one-line diagram by the Project Developer. Transformer connection and secondary grounding to be approved by Utility.
- B) Protection alternatives for the various acceptable transformer connections are shown. Only one protection alternative will ultimately be used, depending on the actual transformer winding connections. VTs for 59, 27, 81o/u and 32 are shown connected on the primary (Project side) of the power transformer, but may instead be connected on the secondary (Utility side). VTs are required on the secondary of the power transformer if a 59N is required for an ungrounded secondary connection. IEEE std 1547 requirements for voltage and frequency must be met at the PCC. IEEE Std. 1547 permits the VTs to be connected at the point of generator connection in certain cases.
- C) Main breaker protection, generator protection and synchronizing equipment are not shown.
- D) Trip of all 52G breakers or the 52M breaker is acceptable, depending upon whether the Project Developer wants to serve its own isolated load after loss of Utility service.

One - Line Diagram

Name of the Licensed Professional Engineer _____
 PE License Number _____
 Address _____
 Signature _____