

SECTION 2

Kinds and Uses of Service 2-1-1 and 2-1-2

Wye Network Area Maps

 Detroit2-1-5

 Ann Arbor2-1-6

 Mt. Clemens2-1-7

 Port Huron.....2-1-8

Transformer Connections and Voltage Relations 2-2-3 to 2-2-14

Definitions--Overhead Lines Construction..... 2-3-1 and 2-3-2

Voltage Regulation Standards 2-4-1 and 2-4-2

USES OF SERVICE**1. Availability of Service or Voltage.**

While desiring and endeavoring to meet promptly and adequately all requests for service, the Company does not hold itself out as prepared to furnish any class of service or voltage not specified in its *Schedule of Rates*. In every case, it is the customer's responsibility to determine whether his equipment is suitable for the service available.

2. Continuity and Quality of Supply.

It is the desire of the Company to furnish continuous and adequate service subject to interruption by agreement, or upon advance notice or by accident or other causes not under the reasonable control of the Company, and except where limitations or hours for controlled service are shown in the *Schedule of Rates*. The Company will not be liable for damages caused by an interruption of service, voltage or frequency variations, single-phase supply to three-phase lines, reversal of phase rotation, or carrier-current frequencies imposed by the Company for system operations or equipment control. Therefore, the customer should install suitable protective equipment if such occurrences might damage his apparatus.

3. Misuse of Company Property.

The Company's wires, poles and apparatus, and the interconnections thereof, are the exclusive property of the Company, and the connection of a customer's premise thereto does not entitle him to any use thereof except such as is necessary in the delivery of the Company's service. The use of any part of the Company's distribution system for carrying foreign electric currents, or for carrier-current transmission or broadcasting, is expressly forbidden unless prior permission has been obtained from the Company.

4. Supply in Excess of 2500 Kilowatts.

The Company does not hold itself out as ready to serve at any location the applicant whose requirements exceed 2500 kilowatts, whether that capacity be installed in one block or arrived at by accretions. Such capacities may require special arrangement by both Company and customer.

5. Low Power Factor.

Loads of low, lagging power factor require increased investment by the Company without adequate compensation and interfere with the voltage regulation of its alternating current circuits. The Company may refuse service to customers whose loads have an average power factor of .70 lagging or less during any one hour. Service shall not be discontinued solely because of low power factor until after sixty days' notice in writing.

6. Alterations and/or Additions to Customer's Equipment.

In order that the customer may receive adequate service and obtain the proper type of equipment, the customer or his contractor should notify the Company of any contemplated changes or additions to his installation and/or utilization of equipment.

7. "Wye" Network Lighting Load Limits.

Customers contemplating a lighting demand of 15 kilowatts or more in the "wye" network areas (see maps on pages 2-1-5 to 2-1-8) should install a 4-wire service and balance the lighting load on all three phases. Consult the appropriate Company Regional Center.

KINDS OF SERVICE**1. Special Services.**

Specialized services are offered for street lighting and municipal pumping. Such services are not available for general use. Consult the Company Regional Center for other special applications.

2. Character of Service.

(a) **Single Phase.** The Company furnishes alternating current service at a nominal frequency of 60 hertz. For lighting and small single-phase power uses, this service is suitable for 120 volt lamps and for domestic appliances nominally rated at 120 or 240 volts.

(b) **Three Phase.** Where available, and when the demand justifies, three-phase, four-wire *wye* connected service may be had at 120/208 volts. Where this service is supplied, it is suitable for 120 volt lamps and for domestic appliances nominally rated at 120 or 208 volts. At its option, the Company may provide 120/240 volt, three-phase, four-wire *delta* connected service or 277/480 volt, three-phase, four-wire *wye* connected service for the customer's entire requirements. Where 277/480 volt service is supplied, the customer must furnish any transformation to supply his 120/240 volt equipment.

3. Alternating Current Underground Network Service.

In certain portions of the central business districts of Ann Arbor, Detroit, Mt. Clemens and Port Huron, alternating current is usually supplied from a "wye" connected secondary network from which 120/208 volt, three-wire or 120/208 volt, three-phase, four-wire service may be taken. Consult maps on pages 2-1-5 to 2-1-8.

GENERAL BOUNDARY LIMITS
ALTERNATING CURRENT "Y" NETWORK AREA

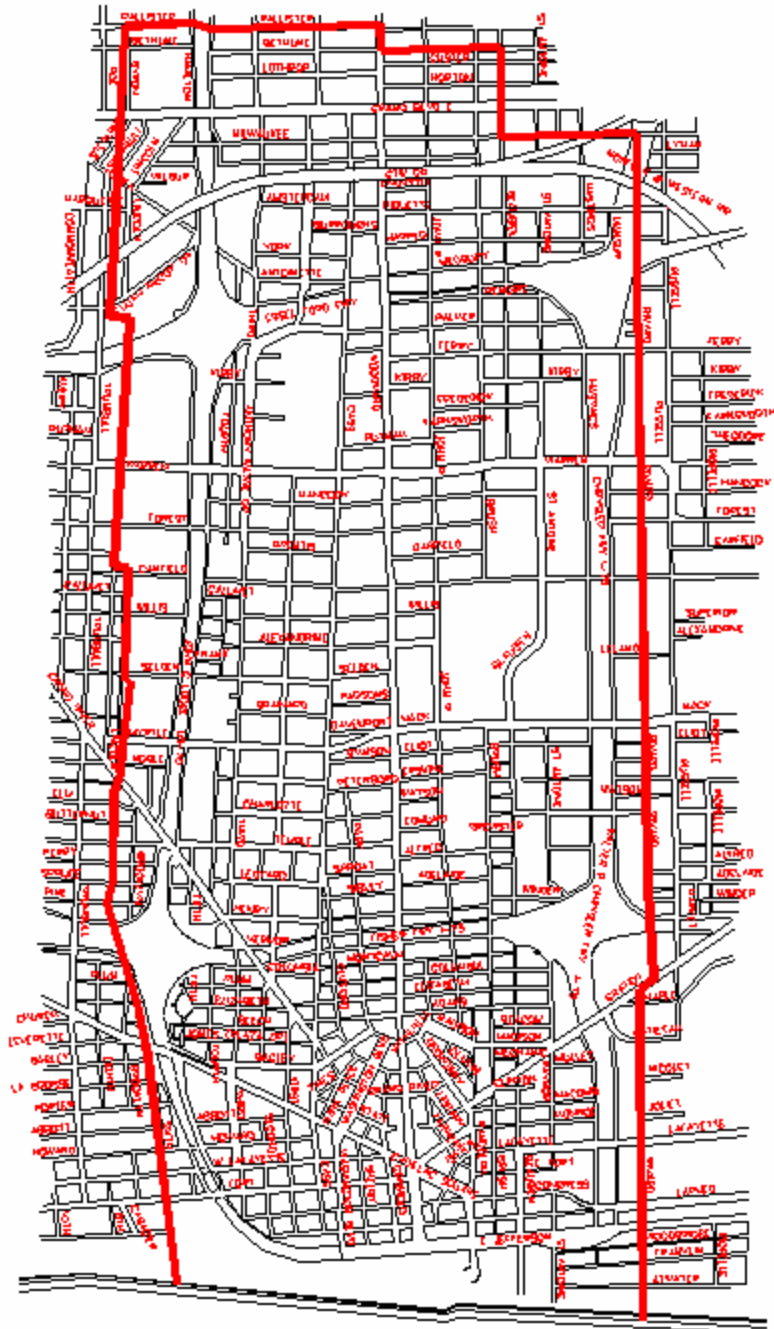

AC "Y" NETWORK AREA

"Y" network secondary service provided at 208/120 volt.
Service is normally underground with some exceptions being overhead.
Choice of service type made by Detroit Edison

ENC 4889C-08
PUBW-2897A-1-5-042

GENERAL BOUNDARY LIMITS
ALTERNATING CURRENT "Y" NETWORK AREA
CITY OF ANN ARBOR

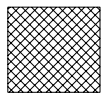
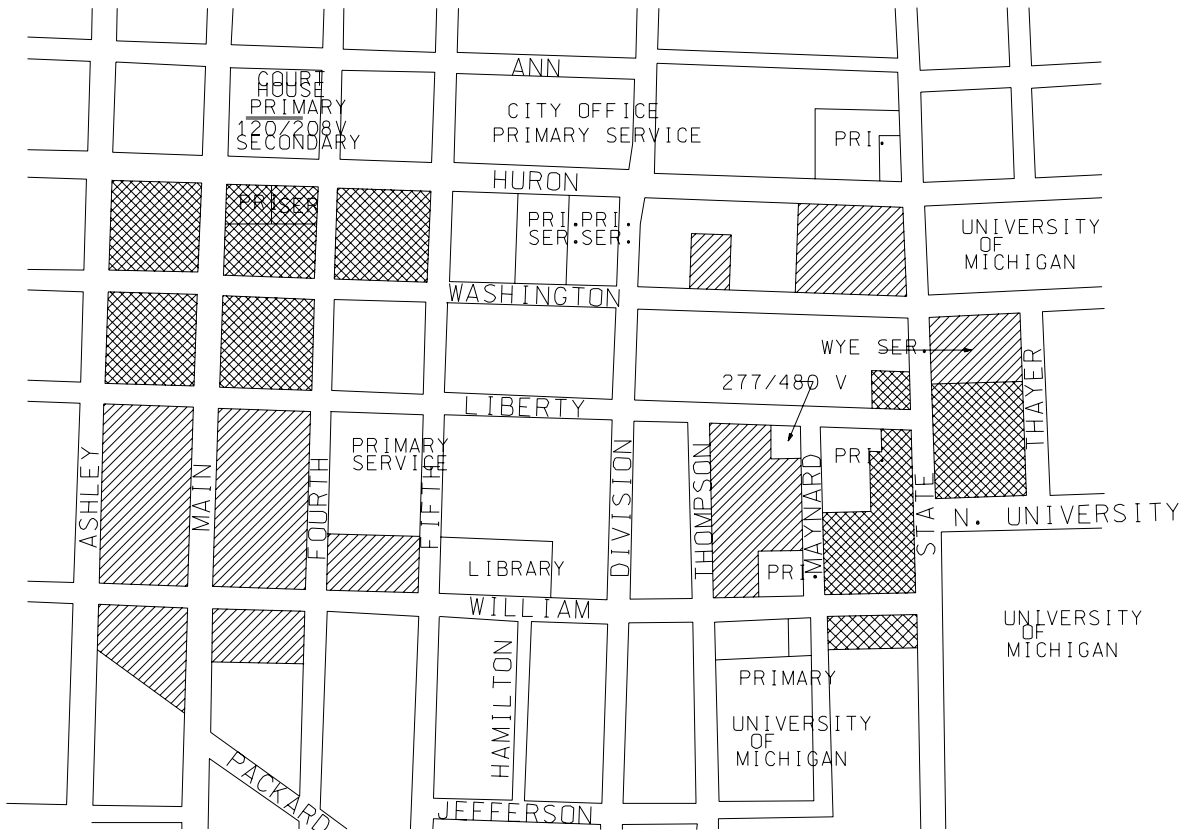

PRESENT "Y" NETWORK AREA

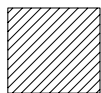



WYE SERVICE FROM
OVERHEAD PRIMARY

AC "Y" NETWORK AREA

"Y" network secondary service provided at 208/120 volt.
Service is normally underground with some exceptions being overhead
Choice of service type made by Detroit Edison.

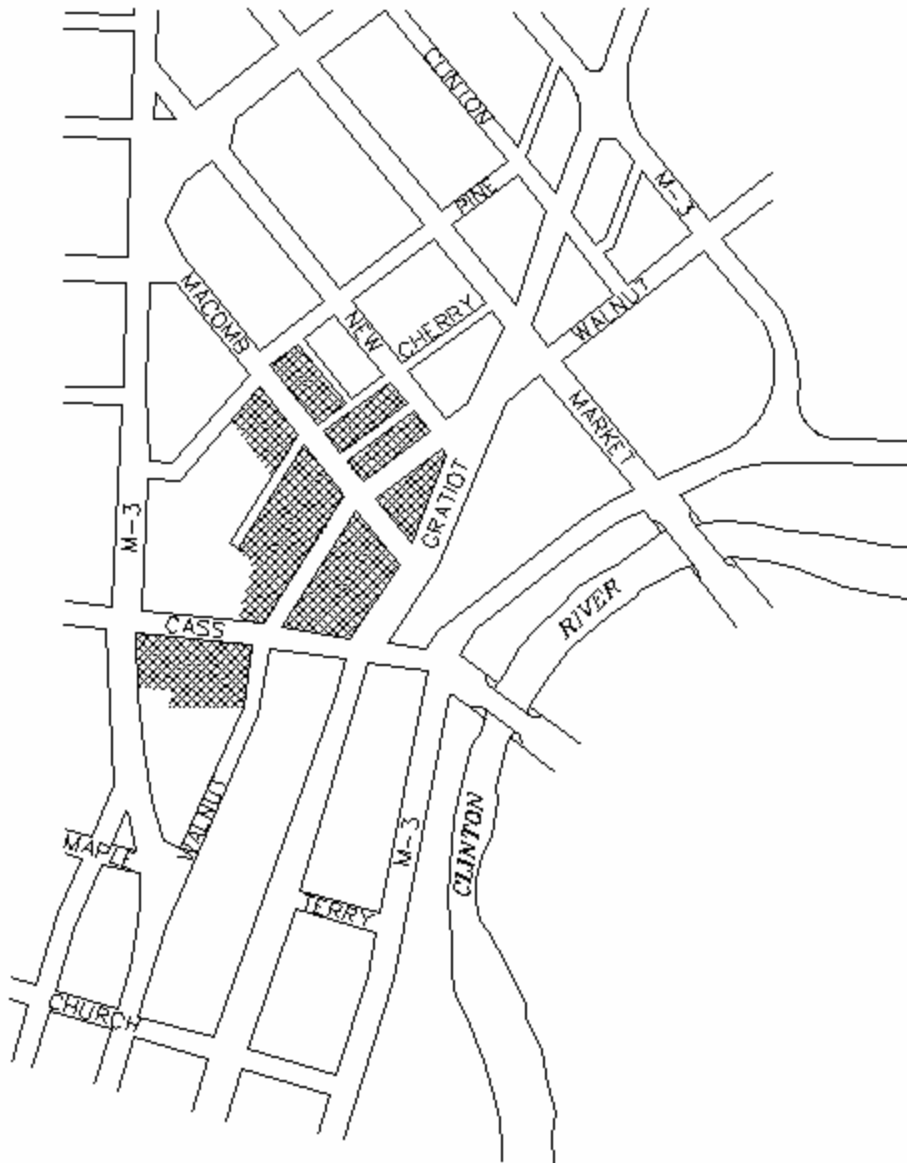
GENERAL BOUNDARY LIMITS
ALTERNATING CURRENT "Y" NETWORK AREA
CITY OF MT. CLEMENS



 PRESENT "Y" NETWORK AREA

AC "Y" NETWORK AREA

"Y" network secondary service provided at 208/120 volt.
Service is normally underground with some exceptions being overhead.
Choice of service type made by Detroit Edison.

DWG. #027-1806
PLUMB-ZONE-1-2,3,4

GENERAL BOUNDARY LIMITS
ALTERNATING CURRENT "Y" NETWORK AREA
CITY OF PORT HURON

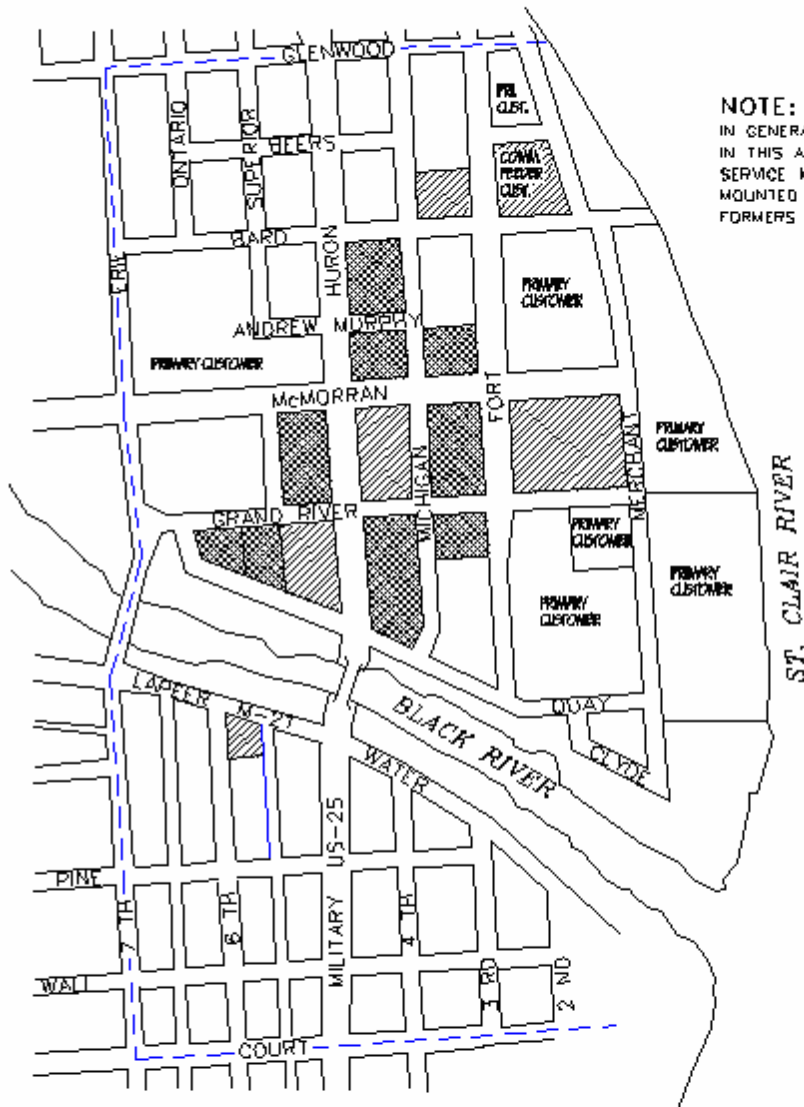

NOTE:
IN GENERAL, NEW OR RENOVATED BUILDINGS
IN THIS AREA WILL BE SERVED 120/208 V. WYE.
SERVICE MAY BE SPOT NETWORK BANK, PAD
MOUNTED TRANSFORMERS OR OVERHEAD TRANS-
FORMERS WITH UNDERGROUND SERVICES.

--- 120/208 V "Y" TRANSITION BOUNDARY



PRESENT "Y" NETWORK AREA



"Y" SERVICE FROM OVERHEAD
OR PADMOUNTED TRANSFORMERS

AC "Y" NETWORK AREA

"Y" network secondary service provided at 208/120 volt.
Service is normally underground with some exceptions being overhead.
Choice of service type made by Detroit Edison.

3000 JULY 1988
PLANNING-2247, 2-7-8-3772

4.8 KV PRIMARY
 TRANSFORMER CONNECTIONS & VOLTAGE RELATIONS
 SINGLE PHASE 3 WIRE SECONDARY LIGHT AND POWER

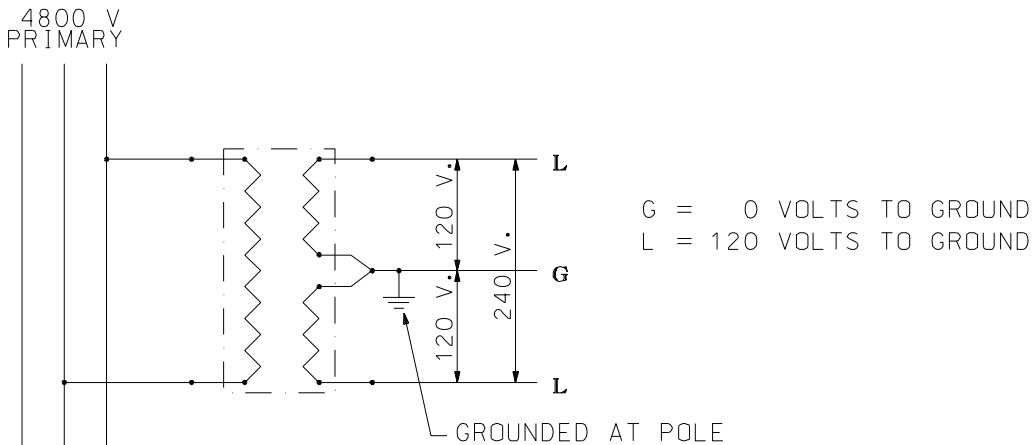

NOTE:
 THIS DIAGRAM IS SCHEMATIC ONLY AND DOES NOT
 SHOW THE ACTUAL POSITION OF WIRES.

4.8 KV PRIMARY
 TRANSFORMER CONNECTIONS & VOLTAGE RELATIONS
 THREE PHASE 4 WIRE DELTA CONNECTED SECONDARY - LIGHT AND POWER

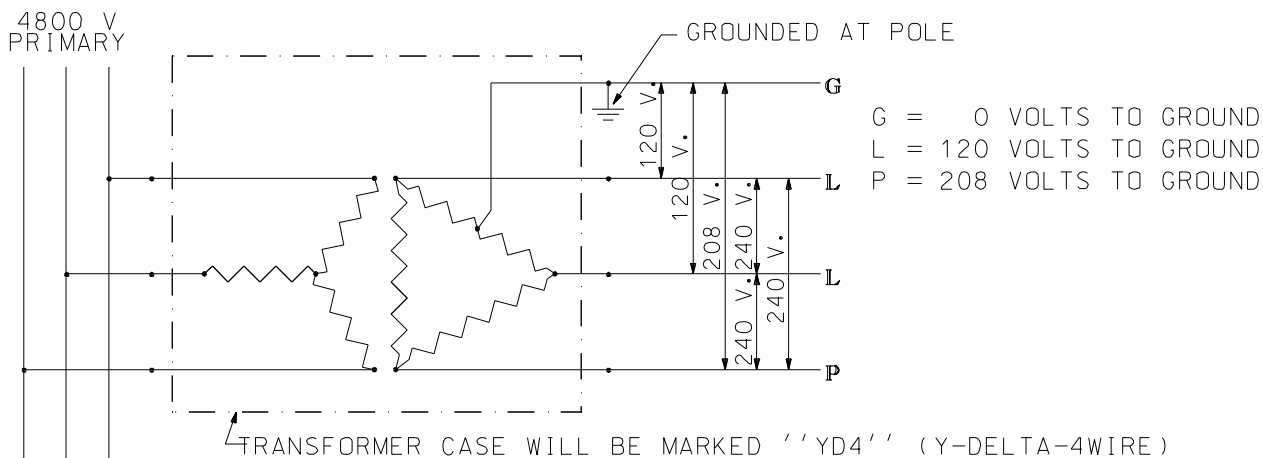

NOTE:
 GROUNDING WIRE IS ON EXTREME
 RIGHT OF TRANSFORMER CASE.
 THIS DIAGRAM IS SCHEMATIC ONLY AND DOES NOT
 SHOW THE ACTUAL POSITION OF WIRES.

4.8 KV PRIMARY
 TRANSFORMER CONNECTIONS & VOLTAGE RELATIONS
 3 PHASE 4 WIRE OPEN DELTA CONNECTED SECONDARY-LIGHT & POWER

4800 V
 PRIMARY

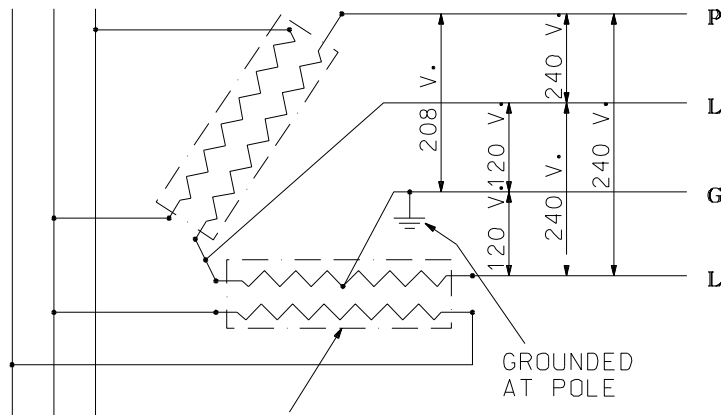

NOTE :

VOLTAGES TO GROUND
 WIRE ARE NOT ALL EQUAL.

G = 0 VOLTS TO GROUND

L = 120 VOLTS TO GROUND

P = 208 VOLTS TO GROUND

ONE OR TWO CASES - IF ONE CASE IS USED
 IT WILL BE MARKED "OD4" (OPEN-DELTA-4 WIRE)

NOTE :

THIS DIAGRAM IS SCHEMATIC ONLY AND DOES NOT
 SHOW THE ACTUAL POSITION OF WIRES.

4.8 KV PRIMARY
 TRANSFORMER CONNECTIONS & VOLTAGE RELATIONS
 120/208 VOLT 3 PHASE 4 WIRE "Y" CONNECTED SECONDARY - LIGHT AND POWER

4800 V
 PRIMARY

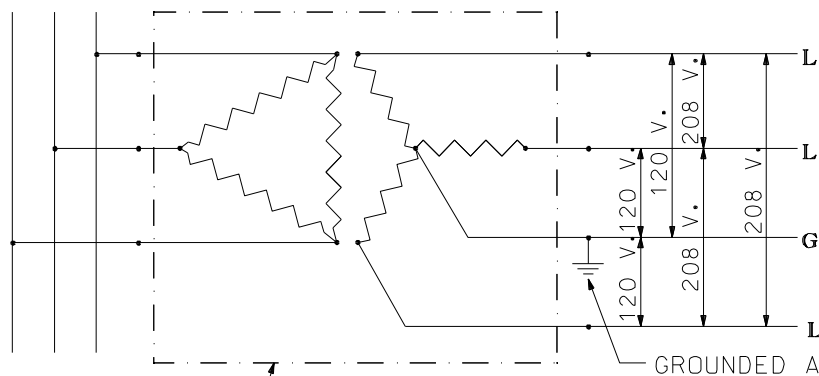

G = 0 VOLTS TO GROUND

L = 120 VOLTS TO GROUND

3 SINGLE PHASE TRANSFORMERS
 IF ONE CASE, MARKED "DY4" (DELTA-Y-4 WIRE)

NOTE :

THIS DIAGRAM IS SCHEMATIC ONLY AND DOES NOT
 SHOW THE ACTUAL POSITION OF WIRES.

4.8 KV PRIMARY
 TRANSFORMER CONNECTIONS & VOLTAGE RELATIONS
 SINGLE PHASE 3 WIRE SECONDARY POWER

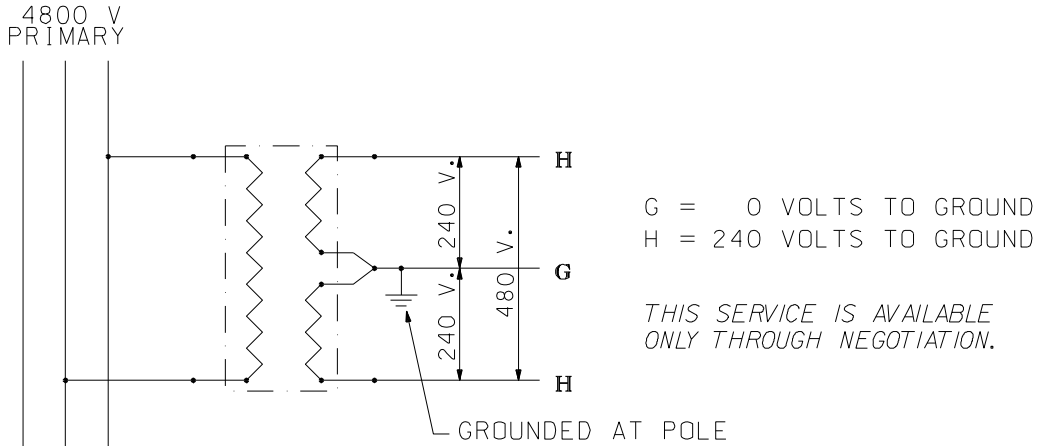

NOTE:
 THIS DIAGRAM IS SCHEMATIC ONLY AND DOES NOT
 SHOW THE ACTUAL POSITION OF WIRES.

4.8 KV PRIMARY
 TRANSFORMER CONNECTIONS & VOLTAGE RELATIONS
 THREE PHASE 4 WIRE DELTA CONNECTED SECONDARY - POWER

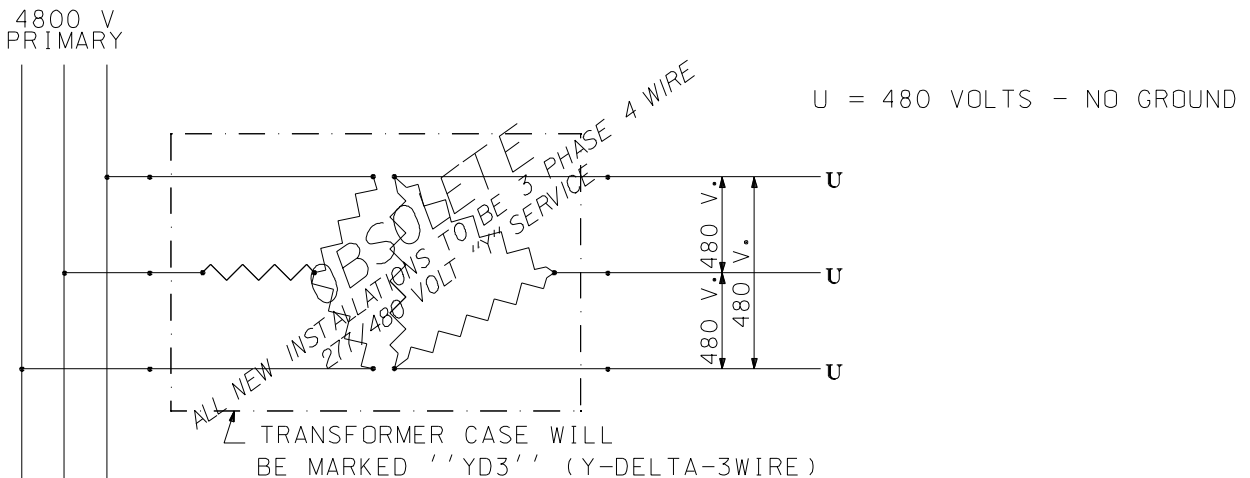

NOTE:
 THIS DIAGRAM IS SCHEMATIC ONLY AND DOES NOT
 SHOW THE ACTUAL POSITION OF WIRES.

4.8 KV PRIMARY

TRANSFORMER CONNECTIONS & VOLTAGE RELATIONS

277/480 VOLT 3 PHASE 4 WIRE ''Y'' CONNECTED SECONDARY - LIGHT AND POWER

4800 V
PRIMARY

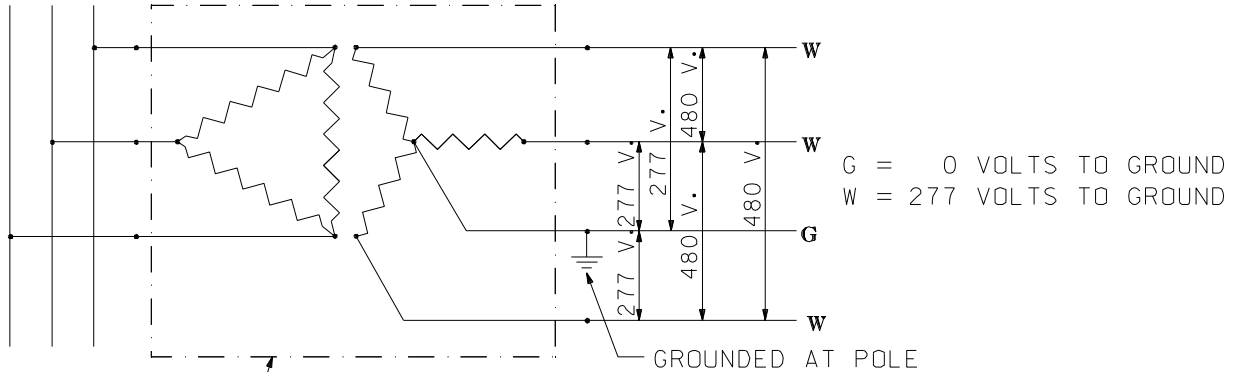

G = 0 VOLTS TO GROUND
W = 277 VOLTS TO GROUND

3 SINGLE PHASE TRANSFORMERS
IF ONE CASE, MARKED ''DY4'' (DELTA-Y-4 WIRE)

NOTE:

THIS DIAGRAM IS SCHEMATIC ONLY AND DOES NOT
SHOW THE ACTUAL POSITION OF WIRES.

13.2 KV PRIMARY - 7.62 KV TRANSFORMER
 TRANSFORMER CONNECTIONS & VOLTAGE RELATIONS
 SINGLE PHASE 3 WIRE SECONDARY LIGHT AND POWER

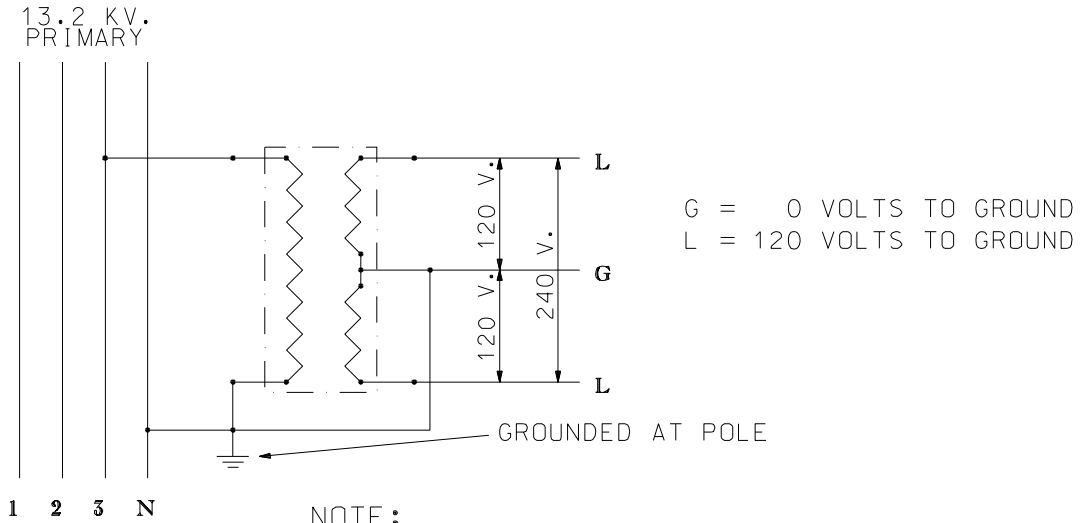

NOTE:
 THIS DIAGRAM IS SCHEMATIC ONLY AND DOES NOT
 SHOW THE ACTUAL POSITION OF WIRES.

13.2 KV PRIMARY - 13.2 KV TRANSFORMER
 TRANSFORMER CONNECTIONS & VOLTAGE RELATIONS
 SINGLE PHASE 3 WIRE SECONDARY LIGHT AND POWER

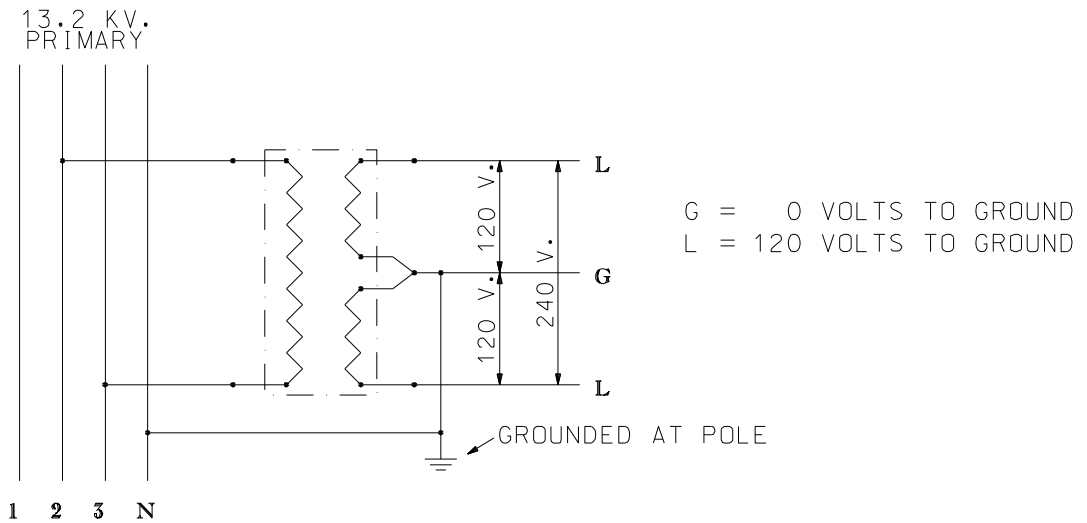

NOTE:
 THIS DIAGRAM IS SCHEMATIC ONLY AND DOES NOT
 SHOW THE ACTUAL POSITION OF WIRES.

13.2 KV PRIMARY - 7.62 KV TRANSFORMERS
 TRANSFORMER CONNECTIONS & VOLTAGE RELATIONS
 3 PHASE 4 WIRE DELTA CONNECTED SECONDARY - LIGHT AND POWER

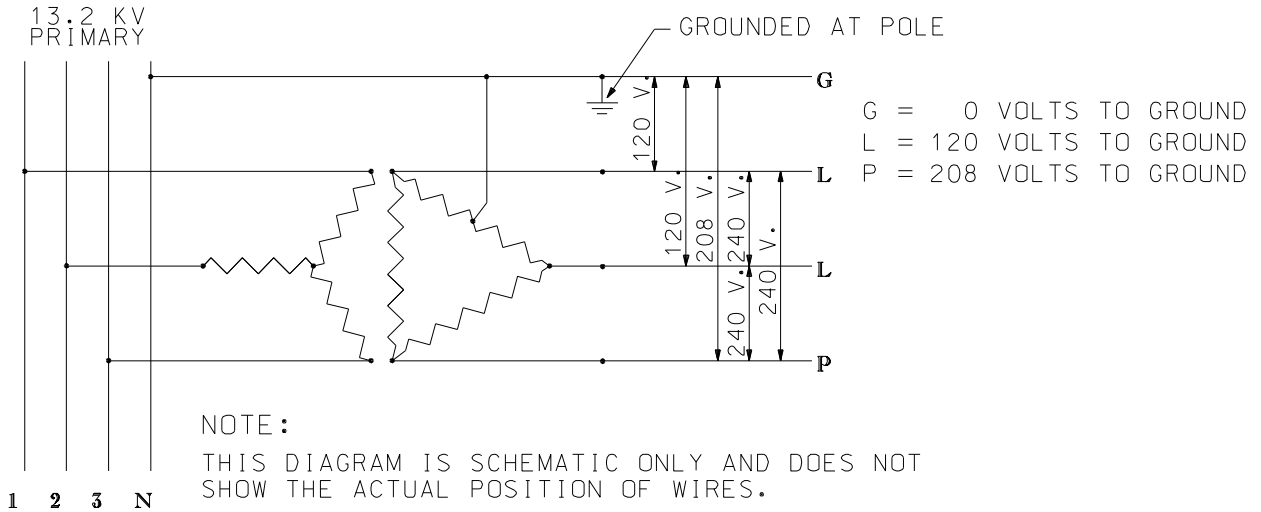

13.2 KV PRIMARY - 13.2 KV TRANSFORMERS
 TRANSFORMER CONNECTIONS & VOLTAGE RELATIONS
 3 PHASE 4 WIRE DELTA CONNECTED SECONDARY - LIGHT AND POWER

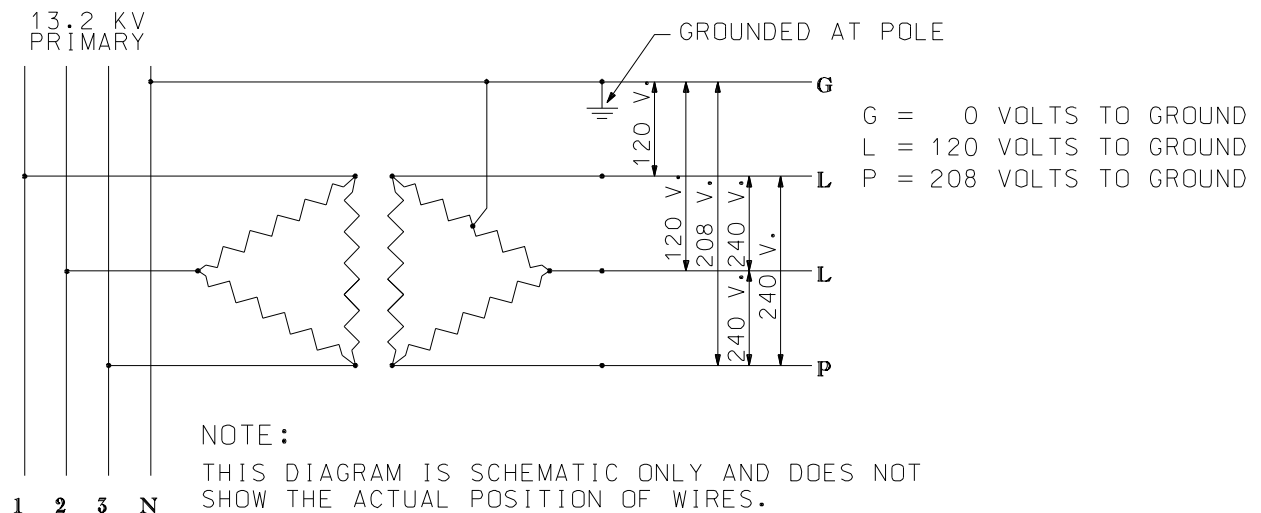

13.2 KV PRIMARY - 7.62 KV TRANSFORMERS
 TRANSFORMER CONNECTIONS & VOLTAGE RELATIONS
 3 PHASE 4 WIRE DELTA CONNECTED SECONDARY - LIGHT AND POWER

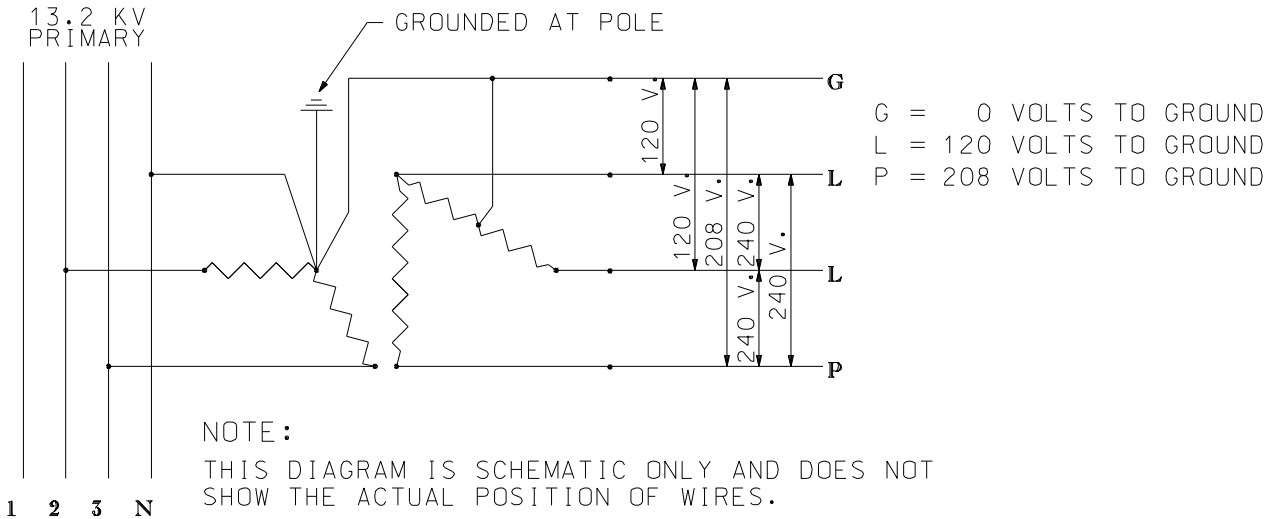

PADMOUNT MAY BE DUPLEX, CONTRACTOR MAY WANT TO PROVIDE THIRD PRIMARY CONDUCTOR FOR FUTURE CLOSED DELTA.

13.2 KV PRIMARY - 13.2 KV TRANSFORMERS
 TRANSFORMER CONNECTIONS & VOLTAGE RELATIONS
 120/208 VOLT 3 PHASE 4 WIRE "Y" CONNECTED SECONDARY - LIGHT AND POWER

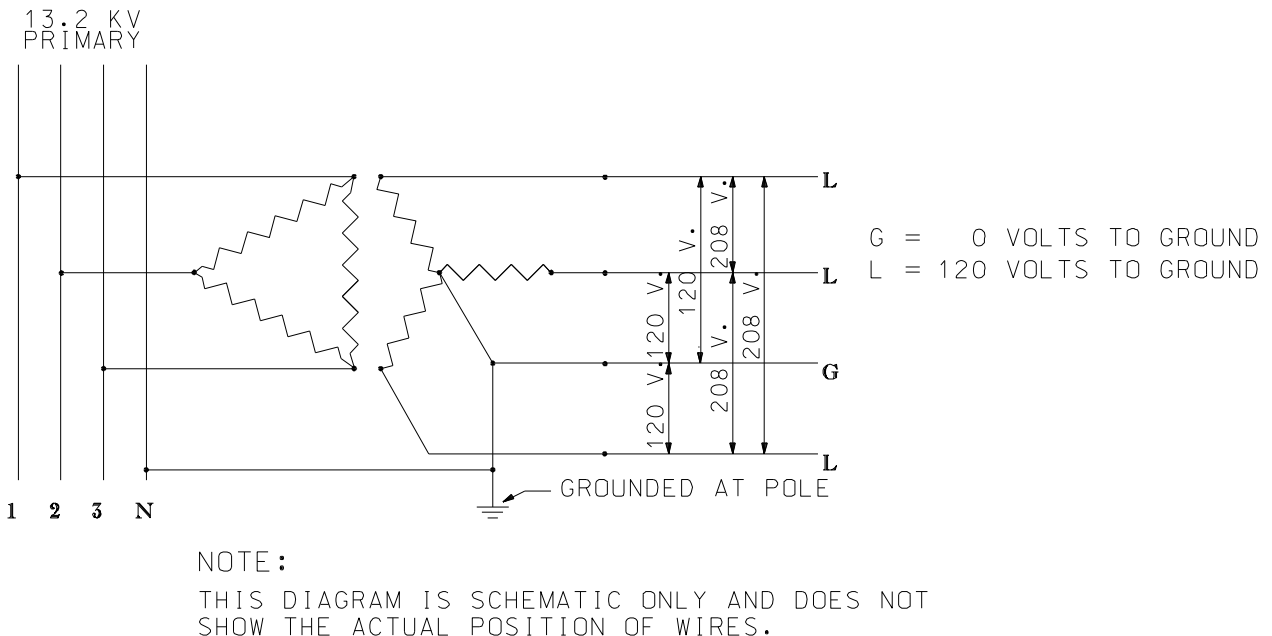

13.2 KV PRIMARY - 13.2 KV TRANSFORMERS

TRANSFORMER CONNECTIONS & VOLTAGE RELATIONS

277/480 VOLT 3 PHASE 4 WIRE "Y" CONNECTED SECONDARY - LIGHT AND POWER

13.2 KV
PRIMARY

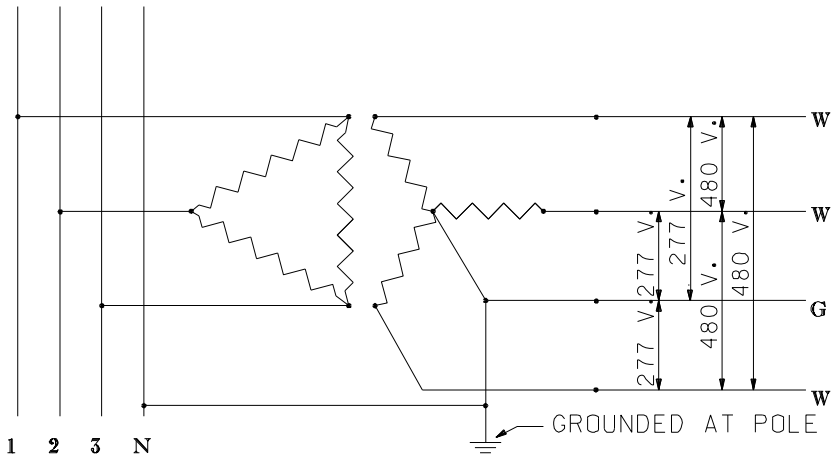

G = 0 VOLTS TO GROUND
W = 277 VOLTS TO GROUND

NOTE :

THIS DIAGRAM IS SCHEMATIC ONLY AND DOES NOT SHOW THE ACTUAL POSITION OF WIRES.

13.2 KV PRIMARY - 13.2 KV TRANSFORMERS

TRANSFORMER CONNECTIONS & VOLTAGE RELATIONS

3 PHASE 4 WIRE "Y" CONNECTED SECONDARY - LIGHT AND POWER

13.2 KV
PRIMARY

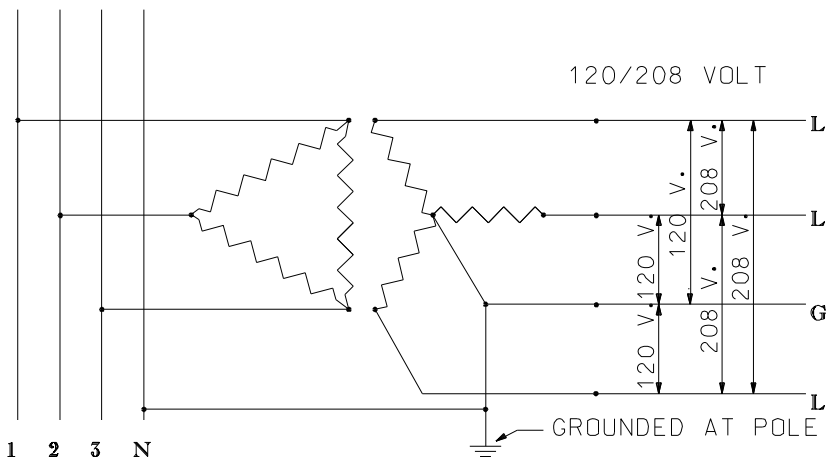

120/208 VOLT

277/480 VOLT

G = 0 VOLTS TO GROUND
L = 120 VOLTS TO GROUND
W = 277 VOLTS TO GROUND

NOTE :

THIS DIAGRAM IS SCHEMATIC ONLY AND DOES NOT SHOW THE ACTUAL POSITION OF WIRES.

13.2 KV PRIMARY - 7.62 KV TRANSFORMERS
 TRANSFORMER CONNECTIONS & VOLTAGE RELATIONS
 ISOLATION TRANSFORMER CONNECTIONS
 SINGLE PHASE 7620 - 4800 OR 4800 - 7620 VOLT

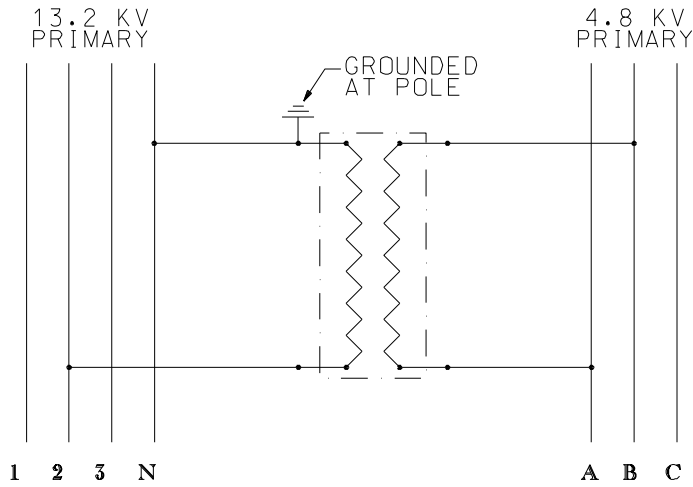

NOTE :

THIS DIAGRAM IS SCHEMATIC ONLY AND DOES NOT SHOW THE ACTUAL POSITION OF WIRES.

13.2 KV PRIMARY - 7.62 KV TRANSFORMERS
 ISOLATION BANK TRANSFORMER CONNECTIONS
 'Y' DELTA 13200 - 4800 VOLT
 (ISO - DN)

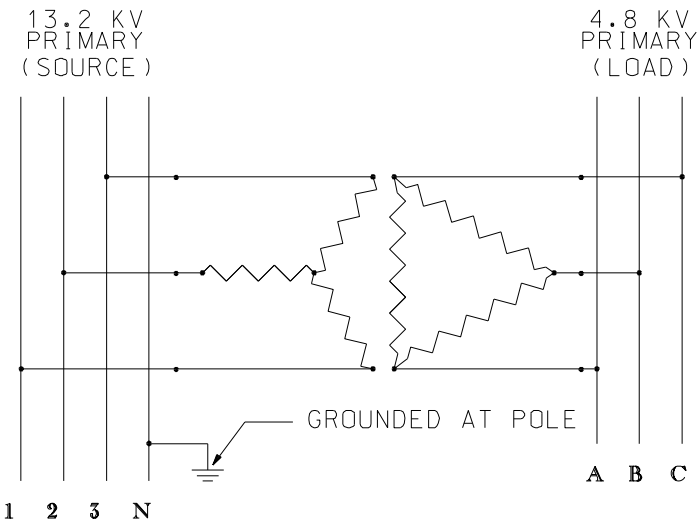

NOTE :

THIS DIAGRAM IS SCHEMATIC ONLY AND DOES NOT SHOW THE ACTUAL POSITION OF WIRES.

13.2 KV PRIMARY - 7.62 KV TRANSFORMERS
ISOLATION BANK TRANSFORMER CONNECTIONS
DELTA ''Y'' 4800 - 13200 VOLT
(ISO - UP)

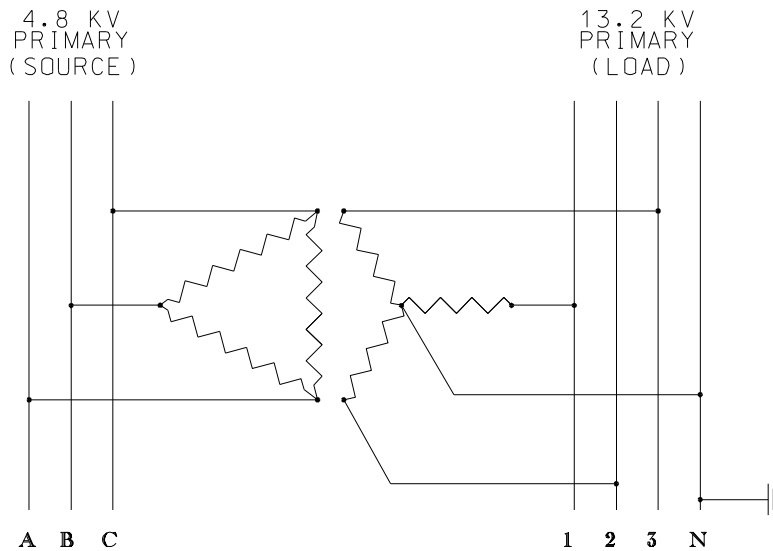

NOTE :

THIS DIAGRAM IS SCHEMATIC ONLY AND DOES NOT
SHOW THE ACTUAL POSITION OF WIRES.

SUB-TRANSMISSION POWER SERVICE
 240 VOLT 2 WIRE SECONDARY
 (FOR SPECIAL SERVICE ONLY)

24 KV OR 40 KV
 TRANSMISSION
 LINE

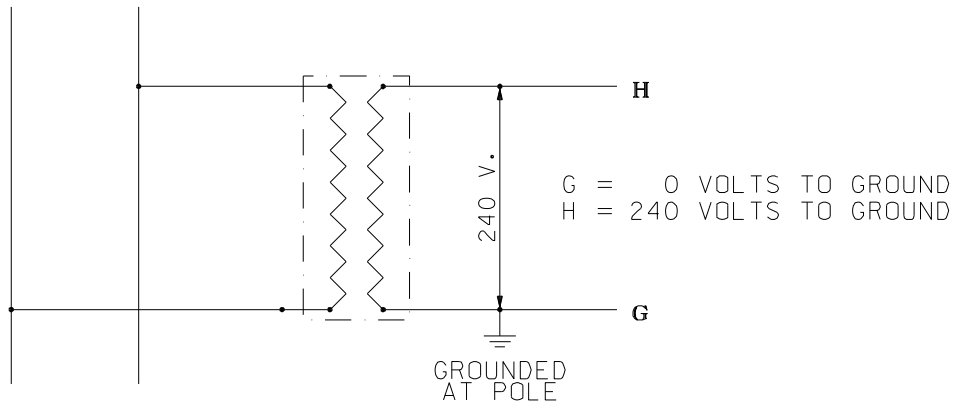

NOTE:
 THIS SERVICE IS AVAILABLE
 ONLY THROUGH NEGOTIATION.

SUB-TRANSMISSION POWER SERVICE
 480 VOLT 3 WIRE SECONDARY
 (FOR SPECIAL SERVICE ONLY)

24 KV OR 40 KV
 TRANSMISSION
 LINE

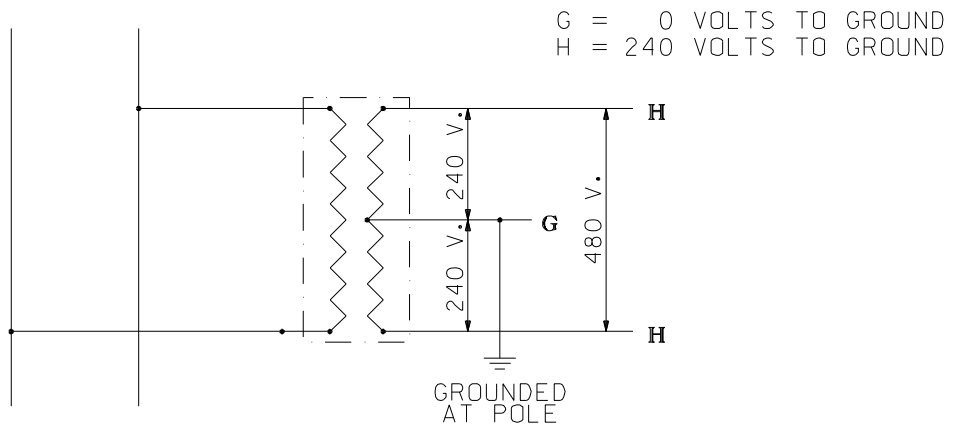

NOTE:
 THIS SERVICE IS AVAILABLE
 ONLY THROUGH NEGOTIATION.

SUB-TRANSMISSION POWER SERVICE
 240 VOLT 3 PHASE 3 WIRE SECONDARY
 (FOR SPECIAL SERVICE ONLY)

24 KV OR 40 KV
 TRANSMISSION
 LINE

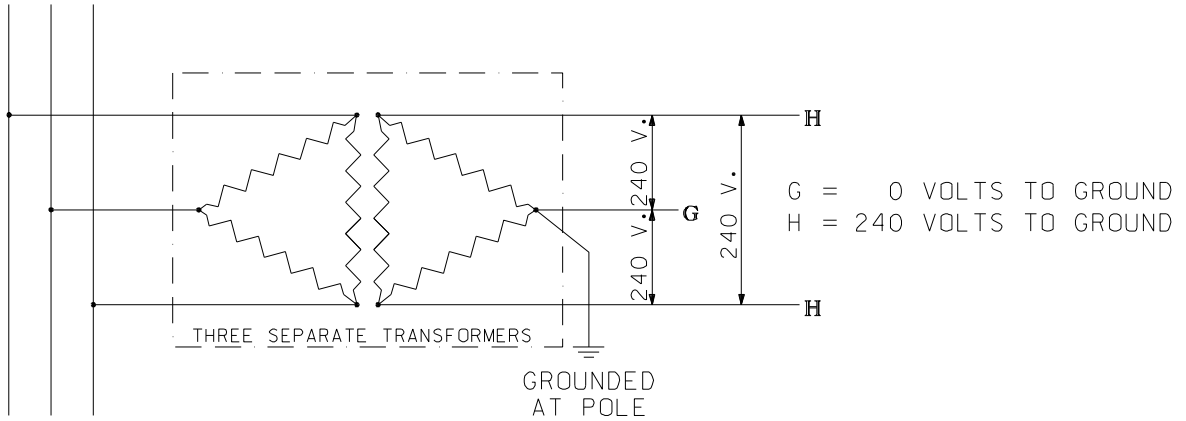

NOTE :
 THIS SERVICE IS AVAILABLE
 ONLY THROUGH NEGOTIATION.

SUB-TRANSMISSION POWER SERVICE
 480 VOLT 3 PHASE 3 WIRE SECONDARY
 (FOR SPECIAL SERVICE ONLY)

24 KV OR 40 KV
 TRANSMISSION
 LINE

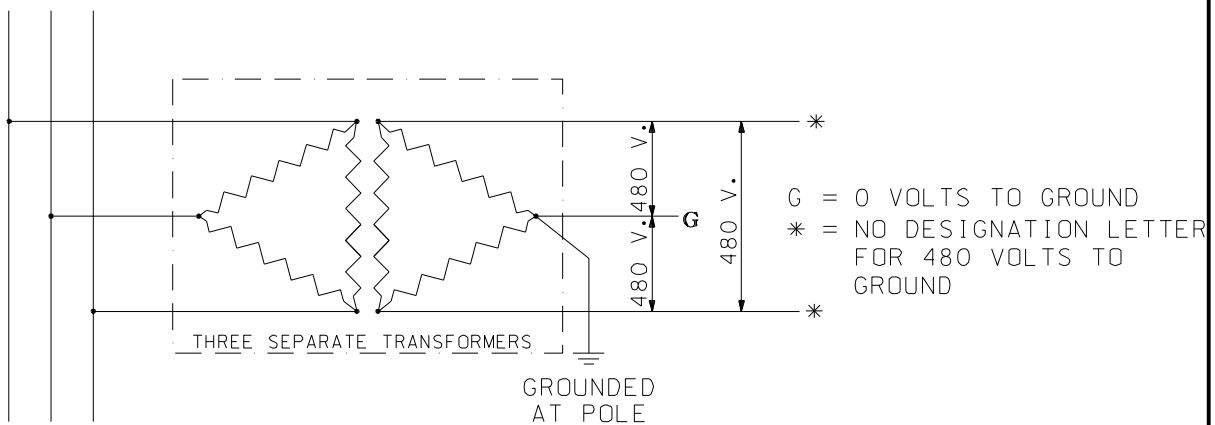

NOTE :
 THIS SERVICE IS AVAILABLE
 ONLY THROUGH NEGOTIATION.

DEFINITIONS

1. **Transmission.** All lines operating at 345, 230 or 120 kV, usually installed on steel towers, steel poles or wood H-Frames.
2. **Subtransmission.** 120 kV lines on wood poles and all lines operating at 40 or 24 kV.
3. **Distribution.** All lines operating at 13.2, 8.3, and 4.8 kV or less, including system data open wire or cable circuits.
4. **Primary.** All 13.2 kV, 8.3 kV (Pontiac Area) and 4.8 kV lines.
5. **Secondary.** Lines operating at 480 V or less, excluding system data circuits. All 480 V secondaries require that a "DANGER 480 V" sign be installed below the rack or on the climbing side of each service buckarm.
6. **Service Drop.** Secondary wires going from the last pole to the building being served. For purposes of identifying wire size, type and construction, one span of wire from a main line feeding one set of drop wires shall be considered as part of the service drop, but shall be reported and shown on facility maps as secondary.
7. **Line Secondary.** Pole to pole secondary wires, either open wire or multiplex, not including service drops.
8. **System Data Circuit.** A Detroit Edison Company owned communication line, either open wire or cable, used for telephone or signal purposes.
9. **Cable Pole.** Any pole on which overhead wires connect to underground cables.
10. **Street Circuit.** A series or multiple circuit that furnishes energy to street lights exclusively.
11. **Open Wire.** Individually supported conductors.
12. **Multiplex.** The assembly of two or more insulated conductors bound to or twisted about a bare supporting wire. These may be either primary or secondary.
13. **Radial Secondary.** Secondary fed by a single transformer or transformer bank and not in parallel with or permanently connected to a second source of voltage.
14. **Private Pole.** A customer-owned pole.

15. **Marking Tags.** Every wood pole shall be identified with a marking tag. This tag shows the ownership, age, height, class and species/treatment. Marking tags will be approximately 7 feet above the groundline on the face side of the pole.
16. **Transformer Bank.** A group of transformers physically arranged together but without restrictions as to the electrical connections.
17. **Secondary Bank.** Two or more transformers or transformer banks connected in parallel along a length of secondary usually, but not necessarily, more than 25 feet apart. There are two types of secondary banks:
 - (a) **Solid Bank.** The secondary is in a continuous run without sectionalizing fuses but with fuses in the connections between the transformer and the line secondary.
 - (b) **Sectionalized Bank.** The line secondary is sectionalized with fuses between adjacent transformers at approximately the neutral point of the load. This configuration is sometimes referred to as a “loose bank.”

Reference: *Overhead Lines Construction Standards*

VOLTAGE REGULATION STANDARDS**1. General.**

- (a) The electrical system will be designed and operated with a view toward maintaining service voltages at the customer's metering point well within the voltage limits given. Any service voltages found to be within these limits shall be considered normal and not subject to corrective measures. If a service voltage is found to be outside limits, steps will be taken to bring it within them.
- (b) All voltage limits shall apply at the customer's metering point. Variations in voltage greater than those specified shall not be considered a violation of these rules if those variations are caused by motor starting currents, welders, furnaces, action of the elements or any momentary and unavoidable fluctuations as may occur with station operation.
- (c) The various types of service available and the recognized voltages pertaining thereto are as follows:

<u>Type of Service</u>	<u>Nominal Voltage</u>	<u>Voltage Limits</u>	
		<u>Minimum</u>	<u>Maximum</u>
240/120 Volt 1Ø	120	114	126
240/120 Volt 3Ø 4W Δ			
Lighting Phases	120	114	126
Phase to Phase	240	228	252
208/120 Volt 3Ø Y (See Note 1)	208Y/120	197Y/114	218Y/126
480/277 Volt 3Ø Y	480Y/277	456Y/263	504Y/291
480 Volt 1Ø or 3Ø	480	See Note 2	(Page 2-4-2)
2400 Volt 3Ø	2400	See Note 2	(Page 2-4-2)
4160 Volt 3Ø	4160	See Note 2	(Page 2-4-2)
4800 Volt 1Ø or 3Ø	4800	4680	5040
6900 Volt 3Ø	6900	See Note 2	(Page 2-4-2)
13,200/7620 Volt 3Ø Y	13,200Y/7620	12,870Y/7430	13,860Y/8000
24,000 Volt 1Ø or 3Ø	24,000	See Note 2	(Page 2-4-2)
40,000 Volt 1Ø or 3Ø	41,570	See Note 2	(Page 2-4-2)
120,000 Volt 3Ø	120,000	See Note 2	(Page 2-4-2)
230,000 Volt 3Ø	230,000	See Note 2	(Page 2-4-2)
345,000 Volt 3Ø	345,000	See Note 2	(Page 2-4-2)
765,000 Volt 3Ø	765,000	See Note 2	(Page 2-4-2)

2. Voltage Unbalance.

Difference in phase voltages will cause unbalanced currents in three-phase motors and raise the operating temperature. If the ratio of the lowest voltage reading to the highest is less than 0.95, corrective steps should be taken.

- Notes:**
1. The tabulated limits apply to suburban service. Nominal 208Y/120 volt service for downtown network areas has limits of 200Y/116 volts minimum and 217Y/125 volts maximum.
 2. The voltage spread for this type of service, which is usually unregulated, will depend upon the requirements of the transmission system. Voltage regulators, if required, will be installed after negotiations between the customer and the Company. Voltage values within which electrical equipment should operate satisfactorily are given in the ANSI C84.1 Standard, *Voltage Ratings for Electric Power Systems and Equipment (60 Hz)*.